

# SHADOWCLAD®

## Specification & Installation Guide

February 2012



## Contents

1.0	Shadowclad Product Range.....	2
1.1	Technical Information and Cad Details .....	2
1.2	Product Description and Range.....	3
1.3	Building Materials for Use with Shadowclad (Exterior Cladding) .....	6
1.4	Preservative Treatment.....	7
1.5	Sustainability.....	7
1.6	Product Identification .....	7
2.0	Design Considerations.....	8
2.1	Design Responsibility.....	8
2.2	Literature Scope .....	8
2.3	Code Compliance .....	8
2.4	Site & Foundations .....	8
2.5	Ground Clearances.....	8
2.6	Moisture Management.....	9
2.7	Wind Loading.....	9
2.8	Durability.....	9
2.9	Textured vs. Smooth Finished Plywood as Exterior Cladding .....	9
2.10	Health & Safety .....	10
2.11	Storage & Handling .....	10
2.12	Limitations.....	10
3.0	Installation - Bracing Specifications... ..	11
3.1	Design to Comply with the New Zealand Building Code .....	11
3.2	Shadowclad Bracing Specifications ..	13
3.3	GIB Handibrac - Recommended Installation Method .....	14
4.0	Installation - Internal Linings.....	15
5.0	Installation - Exterior Cladding.....	15
5.1	Framing - Durability.....	15
5.2	Framing - Construction .....	15
5.3	Preparation - Building Underlay and Rigid Air Barrier .....	15
5.4	Preparation - Direct Fix Construction	15
5.5	Preparation - Cavity Construction..	15
5.6	Sheet Layout .....	18
5.7	Fixings - Fastener Durability .....	18
5.8	Fixings - Fastener Size & Layout.....	18
5.9	Vertical Sheet Joints .....	19
5.10	Horizontal Sheet Joints .....	22
5.11	External Corners .....	23
5.12	Internal Corners.....	24
5.13	Shadowclad Flashing Junction Points..	25
5.14	Window Penetrations .....	26
5.15	Wall Penetrations .....	29
5.16	Sheet Clearances .....	32
5.17	Other Details .....	33
6.0	Coating & Application - Exterior Cladding.....	37
6.1	Surface Penetration.....	37
6.2	Coating Application.....	37
6.3	Coating Selection .....	37
6.4	Shadowclad Coating Requirements if Run Off is Used for Drinking Water ..	37
7.0	Shadowclad Maintenance.....	39
8.0	Frequently Asked Questions.....	40
9.0	References & Sources of Information .....	41

*The information contained in this manual relates specifically to Shadowclad branded structural plywood manufactured by Carter Holt Harvey Woodproducts and cannot be used with any other plywood manufacturers product however similar they may appear.*

*Alternative plywood products can differ in a number of ways which may not be immediately obvious and substituting them for products is not appropriate and could in extreme cases lead to premature failure and/or buildings which do not meet the requirements of the New Zealand Building Code.*

## 1.0 SHADOWCLAD® PRODUCT RANGE

Manufactured by Carter Holt Harvey® Woodproducts, Shadowclad® is suitable for use as an exterior wall cladding when using H3 treated panels or as an internal wall and ceiling lining when using untreated panels.

Shadowclad is manufactured under a third party audited quality control programme to monitor compliance with AS/NZS 2269 Plywood Structural. All Shadowclad products carry Engineered Wood Products Association of Australasia (EWPAA) Joint Accreditation System - Australia and New Zealand (EWPAA/JAS-ANZ) certification.

Shadowclad has been BRANZ appraised as a cladding material for both direct and cavity fixed construction. To view the appraisals visit [www.chhwoodproducts.co.nz](http://www.chhwoodproducts.co.nz).

For information relating to Ecoply® structural plywood and applications other than exterior cladding, refer to the Ecoply Specification & Installation Guide. Or for specific information on plywood as a rigid air barrier, refer to the Ecoply Barrier Specification and Installation Guide.

The Shadowclad BRANZ appraisals do not cover:

- Ecoply Barrier used with Shadowclad
- Shadowclad used as an interior lining
- Downgrade plywood products

### 1.1 TECHNICAL INFORMATION AND CAD DETAILS

When specifying or installing any Shadowclad product visit [www.chhwoodproducts.co.nz](http://www.chhwoodproducts.co.nz) or call 0800 326 759 to ensure you have current specification material.

**Having trouble installing Shadowclad visit [www.chhwoodproducts.co.nz](http://www.chhwoodproducts.co.nz) to view the installation of common Shadowclad junctions.**

## 1.2 PRODUCT DESCRIPTION AND RANGE

Shadowclad® is a structural plywood panel manufactured from radiata pine wood veneers. The veneers are placed at right angles to each other for maximum strength and stability then bonded together with synthetic phenolic (PF) resin to form a strong and permanent Type A bond.

Shadowclad is available in panel sizes 2440 / 2745 x 1200 mm and features a unique textured appearance which also helps to defuse UV rays for increased aesthetic performance when exposed to weather.

Shadowclad is available in either Textured or Texture Groove profiles and in either Natural or Pre Primed finishes.

### Shadowclad® Natural

Shadowclad Natural is an uncoated panel suitable for use with penetrating stains, film forming stains and paint systems.

### Shadowclad® Prime

Shadowclad Prime features a factory applied exterior grade primer suitable for use with most paint and film forming stain systems. Using a unique powder coating process on the panel face and edges Prime panels can be immediately top coated on site, eliminating (in most cases) the need for expensive and time consuming wet primers.

### Shadowclad® Prime features:

- High 70 microns film build, can be up to 2-3 times thicker than traditional wet primers
- Continuous powder coated surface forms an effective moisture barrier for a dryer more consistent painting surface
- Saves time and money as traditional wet primers are not normally required
- Panel surface and edges factory primed for increased panel durability
- Can be exposed to weather for up to 3 months prior to top coat application
- Low volatile organic compound (VOC) primer coating

Shadowclad Prime is available H3 treated for use as an exterior cladding. It is available H3.1 LOSP treated for residential and commercial applications or H3.2 CCA if required.

H3.2 CCA treatment is only available in the Prime finish and is not available with Natural finish products.

Shadowclad Prime is not suitable for use with penetrating stains. For advice on specific coating systems and their suitability for use with Shadowclad Prime always refer to the coating manufacturer.

TABLE 1: SURFACE FINISHES





Natural		Prime	
Texture	Texture Groove	Texture	Texture Groove
			
Shadowclad Natural is an uncoated panel suitable for staining and painting. Panels can also be clear coated when used in internal dry applications.		Shadowclad Prime features a pre primed surface saving time and money when using paints and film forming stains and is suitable for use in exterior applications only.	

TABLE 2: SHADOWCLAD® PRODUCT RANGE

Profile	Texture	Texture Groove
Finish	Natural or Prime	Natural or Prime
Sheet Length	2440 & 2745 mm	2440 & 2745 mm
Width (overall)	1216 mm	1216 mm
Width (effective)	1200 mm	1200 mm
Length/Width Tolerance	+/- 1 mm	+/- 1 mm
Nominal Thickness	12 mm	12 mm
Weight (kg/m <sup>2</sup> )	6.6	6.6
R-value (m <sup>2</sup> .C/W)	0.104	0.104
Groove Profile	N/A	9 mm wide, 5 mm deep at 150 mm centres
Edge Profile	Shiplap with weather groove	Shiplap with weather groove
Treatment Available	<ul style="list-style-type: none"> <li>• H3.1 LOSP (Azole)</li> <li>• H3.2 CCA (Prime finish only)</li> <li>• Untreated- internal dry applications (Natural finish only)</li> </ul>	<ul style="list-style-type: none"> <li>• H3.1 LOSP (Azole)</li> <li>• H3.2 CCA (Prime finish only)</li> <li>• Untreated- internal dry applications (Natural finish only)</li> </ul>

### Downgrade Plywood Cladding

Downgrade plywood cladding (commonly referred to as Utilityclad, Downgrade or Shadowclad® Seconds) may become available during the normal manufacture of Shadowclad panels. Downgrade products may contain sheet defects and visual imperfections and are **not** permitted for use as a cladding material for habitable spaces such as residential and commercial projects.

Downgrade plywood cladding does not meet NZ Building Code durability requirements and are only suitable for use in non habitable buildings such as barns, sheds and general utility buildings.

Downgrade plywood cladding panels are easily identified by markings on the rear of all panels.

For more information on downgrade cladding products refer to information bulletin "Downgrade Plywood Cladding Information Bulletin" downloadable from [www.chhwoodproducts.co.nz](http://www.chhwoodproducts.co.nz)

### Shadowclad® Exterior Flashing Range

Manufactured from extruded aluminium, the Shadowclad flashings range is purpose designed to complement Shadowclad panels used in exterior applications.

Independently tested for weather tightness and compliant with Table 20 of E2/AS1, Shadowclad flashings achieve 50 year durability in all NZS 3604 exposure zones including zone D (sea spray)

The range includes internal and external angles, horizontal and inter-storey 'Z' flashings and a cavity base closure.

Horizontally installed flashings come in 3600 mm lengths and vertically installed angles are available in standard Shadowclad panel lengths.

Flashings not supplied by CHH Woodproducts must comply with E2/AS1 specifications and be compatible for use with H3.1 LOSP or H3.2 CCA treated plywood.

### Flashing Finishes

Shadowclad flashings are available in either natural anodised finish (silver colour) for immediate installation or mill finished allowing customers to powder coat flashings to any desired colour finish.

Visit [www.duluxpowdercoatings.co.nz](http://www.duluxpowdercoatings.co.nz) to find a powder coater in your area or refer to your local yellow pages directory.

### Exterior Flashings & H3.2 CCA Treated Shadowclad®

#### Exposure Zone B & C

H3.2 CCA treated Shadowclad in exposure zones B and C (where flashings are exposed to weather) must use mill finished flashings which must be powder coated to the desired colour or use stainless steel flashings.

H3.2 CCA treatment contains copper. As such, some form of isolation between aluminium flashings and H3.2 CCA treated panels such as powder coating of the flashings is required. Refer to Table 21 "Compatibility of Materials in Contact" in E2/AS1 for more information.

#### Exposure Zone D (Sea Spray)

In exposure zone D (sea spray) flashings exposed to weather must be stainless steel for H3.2 CCA treated Shadowclad.

Stainless steel flashings are not supplied by CHH Woodproducts and must meet requirements of E2/AS1.

Uncoated aluminium flashings are not permitted to be in direct contact in any zone with H3.2 CCA treated Shadowclad which is exposed to weather under any circumstances.

For further information relating to H3.2 CCA treated Shadowclad contact CHH Woodproducts on 0800 746 399

TABLE 3: SHADOWCLAD® FLASHING RANGE



Flashing	Line Drawing	Description	Finish Available	Length (mm)
 <p>Internal 90° Angle</p>		Back flashing for internal corners	Natural Anodised	2440 2745
 <p>Internal 'W' Angle</p>		'W' back flashing for internal corners providing a flush finish with panels (13 mm x 13 mm)	Natural Anodised	2440 2745
 <p>Large Internal 'W' Angle</p>		'W' back flashing for internal corners (25 mm x 25 mm) <b>Design Tip:</b> Use a Large 'W' where a flush junction between the Horizontal 'Z' flashing and corner flashing is desired	Natural Anodised Mill	2440 2745
 <p>External Box Angle</p>		Box corner for external corners providing a flush finish with panels	Natural Anodised Mill	2440 2745
 <p>Large External Box Angle</p>		Box corner for external corners (25 mm x 25 mm) <b>Design Tip:</b> Use Large External Box where a flush junction between the Horizontal 'Z' flashing and corner flashing is desired	Natural Anodised Mill	2440 2745
 <p>Vertical Top Hat</p>		Vertical sheet joint flashing	Natural Anodised Mill	2440 2745

TABLE 3: SHADOWCLAD® FLASHING RANGE CONTINUED

Flashing	Line Drawing	Description	Finish Available	Length (mm)
		Restricts vermin from accessing the cavity space	Natural Anodised	3600
		Horizontal Z flashing for horizontal joints between panels	Natural Anodised Mill	3600
		Horizontal Z flashing for horizontal joints between panels when limiting continuous cavities to a height of two storeys or 7 meters	Natural Anodised Mill	3600

### 1.3 BUILDING MATERIALS FOR USE WITH SHADOWCLAD® (EXTERIOR CLADDING)

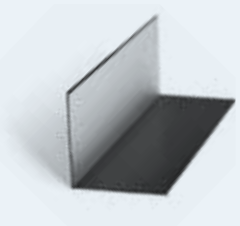
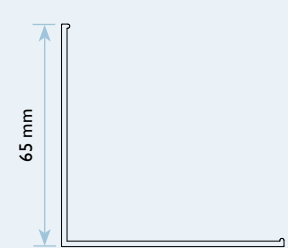
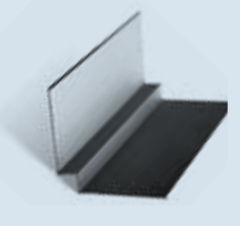
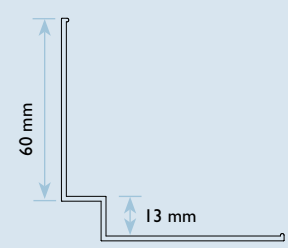
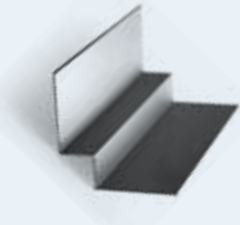
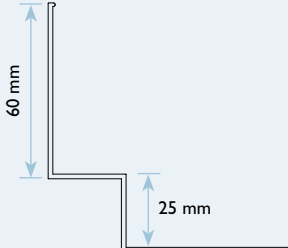
TABLE 4: MATERIALS AVAILABLE FROM CHH WOODPRODUCTS

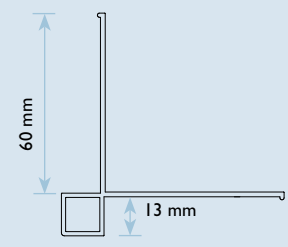
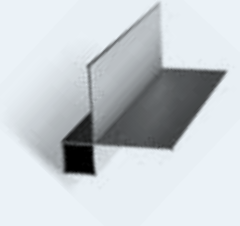
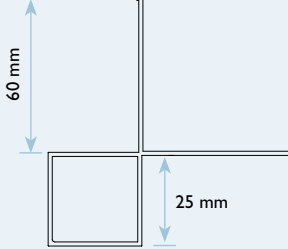
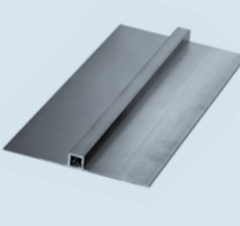
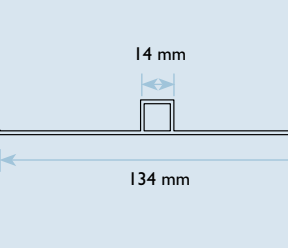
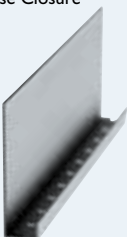
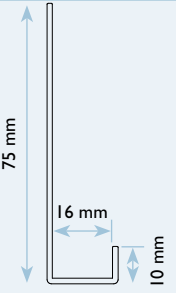
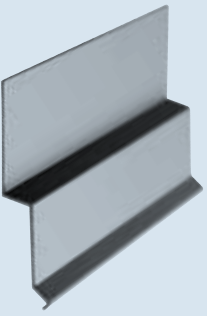
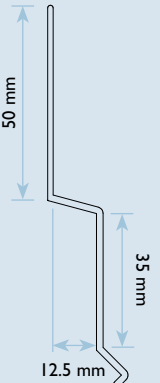
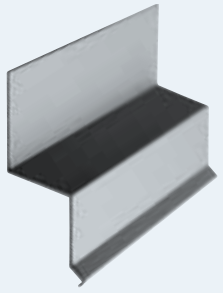
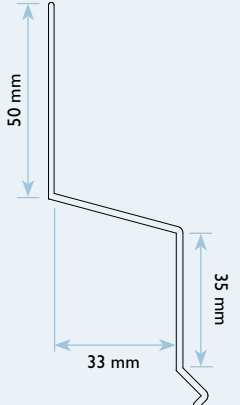
	Description	Treatment	Length
Cavity Battens <sup>1</sup>	47 x 21 mm merch grade 75 x 21 mm merch grade	H3.1 LOSP	Random
Exterior Battens <sup>1</sup> (with 6x6 mm weather grooves)	65 x 18 mm vertical batten (dressed) 65 x 18 mm vertical batten (bandsawn)	H3.1 LOSP	Random
Ecoply® Barrier <sup>2</sup>	Rigid Air Barrier System	H3.2 CCA	2440 / 2745 & 1200 mm

<sup>1</sup> Batten dimensions are nominal

<sup>2</sup> Refer to the Ecoply Barrier Specification and Installation Guide for more information

#### Building Materials Supplied by Other Manufacturers

- Fasteners (i.e. nails or screws) in accordance with Table 8: Fastener Lengths for Shadowclad® fixing
- Building underlay compliant with Table 23 of E2/AS1
- Flexible flashing tape to prepare window openings
- Window/door head flashings supplied by window joinery company
- Window sill flashings (direct fixed only) supplied by window joinery company

## I.4 PRESERVATIVE TREATMENT

Shadowclad® is available either H3 treated for use as an exterior cladding or untreated (Natural finish products only) for interior wall and ceiling linings. H3 treated Shadowclad is treated in accordance with AS/NZS 1604.3 with the standard treatment for Shadowclad panels being H3.1 LOSP (Azole). H3.2 CCA treatment is available for Shadowclad Prime panels if required.

**Shadowclad is envelope preservative treated. Where sheets are cut, cuts must be coated with a brush on timber preservative. Holdfast Metalex Clear is recommended. Failure to do so may affect the long term durability of the panel.**

### H3.1 LOSP Treatment

H3.1 LOSP treatment is the standard treatment for Shadowclad panels as it does not discolour the panel surface and does not use water in the treatment process allowing panels to remain at uniform dimensions.

When coating H3.1 LOSP treated plywood some residual solvent may be present on the sheet surface from the treatment process. Sheets feeling greasy to touch should be placed in a well ventilated area and allowed to flash off to ensure proper adhesion of paints and stains to the sheet surface.

Mechanical fasteners are recommended to fix H3.1 LOSP treated Shadowclad to framing.

### H3.2 CCA Treatment

H3.2 CCA uses water during the treatment process and may leave panel surfaces with a slight green colour. For this reason H3.2 CCA treatment is available only in a pre primed finish (Shadowclad Prime).

TABLE 5: PRESERVATIVE TREATMENT

	Untreated	H3.1 LOSP (Azole)	H3.2 CCA
<b>Preservative carrier</b>	N/A	Light organic oil (white spirits)	Water
<b>Colour</b>	Natural	Natural	Green
<b>Fungicide</b>	Heat treated dry wood	Propiconazole and Tebuconazole	Copper
<b>Insecticide</b>	Heat treated dry wood	Permethrin	Arsenate
<b>Other chemicals</b>	N/A	Butyl Oxitol (co-solvent to assist active stability)	Chrome (to fix preservative in water)
<b>Mouldicide</b>	N/A	IPBC	Copper (limited efficiency)
<b>Notes</b>	Plywood for dry interior use, supplied ex mill at <15% moisture content	Solvent does not affect dimensions. Solvent smell disappears when exposed to air flow	Dried after treatment to average 18% moisture solvent
<b>Applications (Refer NZ3602)</b>	Interior dry protected	Exterior (service performance subject to detailing & coatings used)	Exterior (service performance subject to detailing & coatings used)

## I.5 SUSTAINABILITY

Shadowclad is manufactured from radiata pine. It is grown on tree farms which are tended and harvested to provide wood for plywood manufacture. The crop is managed on a sustainable basis to yield millable trees.

New Zealand plantations are managed in compliance with the New Zealand Forest Accord.

Shadowclad is manufactured in New Zealand at CHH Woodproducts Tokoroa plywood mill.

Shadowclad is available Forestry Stewardship Council (FSC) (SCS-COC-001316) certified upon request.

## I.6 PRODUCT IDENTIFICATION

In accordance with AS/NZS 2269, every sheet of Shadowclad plywood has the following information marked on the back:

- Brand name: e.g. SHADOWCLAD
- Glue bond: e.g. A BOND
- Intended application: e.g. STRUCTURAL
- Australasian Standard: e.g. AS/NZS 2269:2008
- Date and time of manufacture: e.g. 01/01/12 19:45:45
- Formaldehyde emission class: E<sub>0</sub>
- The Engineered Wood Products Association of Australasia

(EWPA) brand and mill number: e.g. 911 (Tokoroa mill)

**For example:**

SHADOWCLAD A BOND STRUCTURAL  
AS/NZS 2269:2008 PAT 01/01/12 19:45:45 E0



If the plywood is treated it will also be marked in accordance with the treatment standard AS/NZS 1604.3

## 2.0 DESIGN CONSIDERATIONS

### 2.1 DESIGN RESPONSIBILITY

The specifier for the project must ensure that the details in the specification are appropriate for the intended application and that additional detailing is provided for specific design or any areas that fall outside the scope and specifications of this literature.

Good detailing which avoids moisture or dust accumulation on the sheet surface can help increase durability and aesthetics.

Roof overhangs contribute to performance as they offer shade and will protect walls from rain and dust. Trims should be bevelled to shed moisture and flashings should be detailed with gaps that do not trap water at the panel edges.

### 2.2 LITERATURE SCOPE

Shadowclad® can be used for those structures which fall within the scope of Acceptable Solution E2/AS1 "External Moisture". There are two methods of installing Shadowclad depending on the risk assessment for each wall face to be clad:

- Direct-fixed, where the cladding is fixed directly to the timber frame
- Drained and ventilated cavity, where the cladding is fixed onto timber battens fixed over the timber frame

Details in this publication reference cavity fixed applications only. Direct fix details can be downloaded from [www.chhwoodproducts.co.nz/shadowclad-plywood-cladding](http://www.chhwoodproducts.co.nz/shadowclad-plywood-cladding)

To determine which fixing method is required by the Acceptable Solution, assess each wall face using the building envelope risk matrix in 'E2/AS1 - External Moisture' (latest edition). For each wall with a risk score of 0 - 6, Shadowclad can be direct-fixed and where the risk score is 7 - 20, Shadowclad must be fixed over a drained and ventilated cavity.

### 2.3 CODE COMPLIANCE

Shadowclad is tested in accordance with E2/VMI and NZS4284 "Testing of Building Facades" for compliance with NZ Building code requirements.

### 2.4 SITE & FOUNDATIONS

The site on which the building is situated must comply with the Acceptable Solution E1/AS1 of the Approved Document

for the NZBC (New Zealand Building Code) Clause E1 "Surface Water".

### 2.5 GROUND CLEARANCES

The bottom edge of the Shadowclad sheet must be a minimum of 100 mm above decks or paved ground and a minimum of 175 mm above unprotected ground.

Shadowclad must overhang the bottom plate on a concrete slab by a minimum of 50 mm as required by NZS 3604.

For garage door openings, refer Paragraph 9 "Openings to garages" in Acceptable Solution E2/AS1.

## 2.6 MOISTURE MANAGEMENT

It is the responsibility of the specifier to identify moisture related risks associated with any particular building design.

Wall construction design must effectively manage moisture, accounting for both the interior and exterior environments of the building. This is particularly important in buildings that have a higher risk of wind driven rain penetration or that are artificially heated or cooled.

Where a deck is attached to the building and the Shadowclad® extends below the deck to cover the framing, keep decking clear of

the Shadowclad surface and detail to avoid moisture entrapment.

All wall openings, penetrations, junctions, connections, window sills, heads and jambs must incorporate appropriate flashing and waterproofing. Materials, components and the installation used to manage moisture in framed wall construction must, at a minimum, comply with the requirements of relevant Sections and Clauses of the NZ Building Code.

## 2.7 WIND LOADING

Shadowclad is suitable for use in all wind zones up to and including extra high (55m/s) as defined by NZS 3604 and

specific design wind pressures up to design differential ultimate limit state (ULS) of 2.5 kPa.

## 2.8 DURABILITY

The durability level applicable to Shadowclad is dependent upon the application and coating applied. Detailing, treatment and installation methods need careful consideration to satisfy the requirements of the NZ Building Code.

### Internal Linings - 50 year Durability

Untreated Shadowclad used in dry, interior situations will meet the requirements for 50 year minimum durability left coated or uncoated.

### Exterior Cladding - 50 year Durability

To meet the requirements for a 50 year minimum durability level, when used as an exterior cladding (as per NZ Building Code Clause B2 for claddings used as bracing or structural element) Shadowclad panels must be:

- H3 preservative treated
- Coated with a 3 coat acrylic coating system such as a good quality paint or film forming stain system. (Penetrating stains do not meet this requirement)
- Coating colours must have a light reflectance value (LRV) of 40% or more
- Minimum total coating system film build of 90 microns
- Coating must be regularly maintained as part of a normal building maintenance program throughout the life of the building

Advice and assurances from the coating manufacturer must be sought and details submitted for approval with any building consent application to ensure the applicable requirements for 50 year durability are achieved.

For further information on Shadowclad used as both cladding and bracing refer to section: 3.0 Bracing Specifications.

### Exterior Cladding - 15 year Durability

NZ Building Code Clause B2 requires claddings which do not form part of the bracing or structural element to achieve a minimum structural durability level of 15 years.

Shadowclad coated with stains or paints (regardless of colour choice) will meet this requirement. If using dark colours (colours with an LRV of less than 40%) homeowners should expect an increased level of coating maintenance over the life of the cladding than would normally be expected where lighter colours are used.

Failure to adequately maintain the surface coating of the cladding is unlikely to affect the durability of the panel however the risk of aesthetic related issues such as face checking are increased and are not covered by manufacturer durability obligations under the NZ Building Code.

**CHH Woodproducts does not recommend Shadowclad is left uncoated when used as an exterior cladding.**

For further advice on coatings selections refer to section 6.0: Coating and Application - Exterior Cladding.

## 2.9 TEXTURED VS. SMOOTH FINISHED PLYWOOD AS EXTERIOR CLADDING

Structurally, some smooth faced plywood products may meet the requirements of E2/AS1 however in CHH Woodproducts opinion smooth faced plywood does not retain a high appearance when directly exposed to external weather.

Where a high appearance is desired (such as exterior cladding) CHH Woodproducts recommends the use of Shadowclad over smooth faced plywood. Shadowclad features a textured

(bandsawn) face which reduces the visibility of natural surface checking which can occur in any wood based product which has been exposed to weather for a prolonged period.

Surface checks are not considered a manufacturing fault as they are part of a natural process and are merely an indication that it is time to re-apply the surface coating on the product.

## 2.10 HEALTH & SAFETY

---

Shadowclad® should be installed and used as per the Material Safety Data Sheet (MSDS) downloadable from [www.chhwoodproducts.co.nz](http://www.chhwoodproducts.co.nz).

Always wear safety glasses or non-fogging goggles when cutting Shadowclad panels and aluminium flashings.

If wood dust exposures are not controlled when machining (sawing, routing, planing, drilling etc) a class P1 or P2 replaceable filter or disposable face piece respirator should be worn.

Wear comfortable work gloves to avoid skin irritation and the risk of splinters. Wash hands with mild soap and water after handling panels.

## 2.11 STORAGE & HANDLING

---

### Shadowclad® panels:

- Keep Shadowclad panels dry
- Store under cover
- Handle and stack with care to avoid damage.
- Stack flat; clear of ground, on at least three evenly spaced bearers
- Store in well-ventilated areas away from sources of heat, flames or sparks

### Shadowclad® flashings:

- Keep dry. Should a shipment of Shadowclad flashings arrive in a wet condition, they should be immediately dried before storing
- When storing aluminium avoid contact with other metals which may cause scratches or marks. The use of shelving or racks faced with dry wood is recommended
- Keep away from caustics, nitrates and acids

## 2.12 LIMITATIONS

---

The information contained in this document is current as at February 2012 and is based on data available to CHH Woodproducts at the time of going to print.

All photographic images are intended to provide a general impression only and should not be relied upon as an accurate example of Shadowclad installed in accordance with this document or NZ Building Code compliance documents.

This publication replaces all previous CHH Woodproducts design information and literature relating to Shadowclad panel installation and flashings. CHH Woodproducts reserves

the right to change the information contained in this document without prior notice. It is important that you visit [www.chhwoodproducts.co.nz](http://www.chhwoodproducts.co.nz) or call 0800 326 759 to confirm that you have the most up to date information available.

CHH Woodproducts has used all reasonable endeavours to ensure the accuracy and reliability of the information contained in this document and, to the extent permitted by law, will not be liable for any inaccuracies, omissions or errors in this information nor for any actions taken in reliance on this information.

## 3.0 BRACING SPECIFICATIONS

The Shadowclad® bracing system provides bracing resistance for walls and subfloor foundations for light timber framed buildings under wind and earthquake loading, to meet the requirements of the NZ Building Code - B1 Structure, and NZS 3604 *Timber Framed Buildings* or specifically designed to NZS 3603 *Timber Structures Standard*.

Any Shadowclad structural panel may be used for bracing provided the Shadowclad bracing specifications outlined in this publication are followed.

Shadowclad panels may be used as a dual cladding and structural bracing system either direct fixed or over a ventilated cavity.

Where Shadowclad is to be used as both cladding and structural bracing the following is required:

- Panels must be coated with a three coat acrylic coating system such as a good quality paint or film forming stain. (Penetrating stains do not meet this requirement)
- Coating colours must have light reflectance value (LRV) of 40% or more
- Minimum total coating system film build of 90 microns
- The coating must be regularly maintained as part of a normal building maintenance program throughout the life of the building

## 3.1 DESIGN TO COMPLY WITH THE NEW ZEALAND BUILDING CODE

### Structure

#### Timber framed buildings to NZS 3604

NZS 3604 *Timber Framed Buildings* is listed as an Acceptable Solution under clause 3.0 Timber in Acceptable Solution B1/AS1 Structure.

CHH Woodproducts have developed a range of wall bracing elements tested using P21 testing methods referenced in NZS 3604:2011.

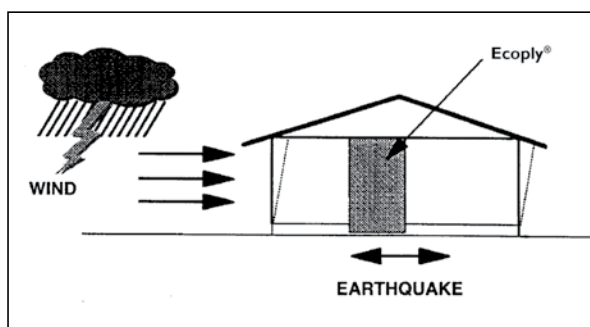

#### Specific design

Because Shadowclad is structural plywood manufactured to AS/NZS 2269, it is suitable for design and use in earthquake and wind bracing systems constructed in accordance with NZS 3603 and AS/NZS 1170.

Structural plywood to AS/NZS 2269 is the only sheet brace material with properties defined in a published New Zealand engineering design code, NZS 3603 *Timber Structures*, and so

can be designed in compliance with Verification method B1/VM1 under clause 6.0 Timber for use in buildings over three storeys in height.

Demand is calculated by following Section 5, Bracing Design of NZS 3604 or using the GIB Ezy-Brace software, downloadable from [www.gib.co.nz](http://www.gib.co.nz)

#### Timber Floors

When carrying out a bracing design for buildings with timber floor structures, the maximum bracing rating that can be accounted for when summing up the bracing units is 120 BUs/m. This does not exclude the installation of bracing elements that are rated higher than 120 BUs/m, however the extra bracing capacity can not be accounted for in the bracing design.

Specific design of floor and sub-floor framing is required for elements rated higher than 120 BUs/m if the full element rating is to be accounted for.

#### Durability

Shadowclad plywood is manufactured to meet the requirements of NZS 3602 Timber and Wood based products for use in Buildings. If the product is used, handled and installed in accordance with CHH Woodproducts product literature it will meet the durability clauses of the NZ Building Code.

Table 6 summarises the applications in which Shadowclad can be used as structural bracing together with the preservative treatment and fastener material required.

**TABLE 6: SHADOWCLAD® SUITABILITY FOR BRACING APPLICATIONS INCLUDING TREATMENT TYPE AND FASTENER MATERIAL**

Application	Plywood Treatment	Fastener Material
<b>Shadowclad® bracing exposed to exterior weather conditions and dampness but not in contact with ground in exposure zones<sup>1</sup> B &amp; C:</b> E.g. Shadowclad used as both cladding and bracing (direct fixed to framing or over a drained ventilated cavity system)	Shadowclad H3.1 LOSP	Hot dipped galvanised or better
	Shadowclad H3.2 CCA	Stainless steel
<b>Shadowclad bracing exposed to exterior weather conditions and dampness but not in contact with ground in exposure zones<sup>1</sup> D (sea spray):</b> E.g. Shadowclad used as both cladding and bracing (direct fixed to framing or over a 20 mm drained ventilated cavity system)	Shadowclad H3.1 LOSP	Stainless steel
	Shadowclad H3.2 CCA	

<sup>1</sup> Exposure zones as per section 4 of NZS 3604

### Subfloor sheet bracing

H3 treated Shadowclad can be used as sheet bracing where dampness does not allow the use of untreated plywood or other sheet materials (section 5 of NZS 3604). Where Shadowclad subfloor sheet bracing is exposed to both rain and sun, it must be coated with a three coat, maintained acrylic exterior coating system with a light reflectance value of 40% or greater.

### Adjustments for wall height

Use section 5 of NZS 3604 to calculate bracing values:

“Adjustment of bracing capacity of walls of different heights and walls with sloping top plates shall be obtained by the following method:

- For wall bracing elements of heights other than 2.4 m, the bracing rating determined should be multiplied by  $2.4 \div \text{element height in metres}$ , except that elements less than 2.4 m high shall be rated as if they are 2.4 m high.
- Walls of varying heights, should have their bracing capacity adjusted in accordance with section 5 of NZS 3604 using the average height.”

### Joining panels for walls higher than maximum sheet length

Shadowclad bracing panels must be fixed from top plate to bottom plate. For wall heights over 2.45 m, Shadowclad is available in 2.745 m sheet lengths. Alternatively, a part sheet can be stacked above a full sheet, butt joined on a single row of nogs with each sheet/part sheet independently nailed off as per the nail spacing in the Shadowclad bracing specifications.

### Cladding as bracing

Shadowclad is recommended as a cladding which can be used for bracing as well.

12 mm Ecoply® (CD face grade or better) can be H3 treated to meet the requirements of Acceptable Solution E2/AS1 and will perform as a structural, durable and weather tight cladding and bracing element when installed in accordance with the specifications in this Guide.

However smooth faced plywood such as Ecoply may be prone to appearance related issues such as face checking which occurs naturally and is not considered by CHH Woodproducts to be a manufacturing or product fault.

For exterior cladding applications where a high visual appearance is desired, CHH Woodproducts strongly recommends the use of Shadowclad as an exterior cladding.

### Soil

Shadowclad must not be allowed to come in contact with soil. The bottom edge of the plywood sheet must be a minimum of 100 mm above decks or paved ground and a minimum of 175 mm above unprotected ground.

### Service penetrations in bracing elements

Small openings (e.g. power outlets) of 90 x 90 mm or less may be placed no closer than 90 mm to the edge of the braced element, or waste pipe outlets of max. 150 mm diameter placed at no closer than 150 mm to the edge of the braced element.

## 3.2 SHADOWCLAD® BRACING SPECIFICATION – SCI

### SINGLE SIDED SHADOWCLAD® BRACE

Specification No.	Minimum Wall Length	Lining Requirements	BU's/m Wind	BU's/m Earthquake
SCI	0.6 m	Shadowclad one side	105	120

#### Framing

Wall framing must comply with:

NZBC B1 - Structure: ASI Clause 3 Timber (NZS 3604:2011)

NZBC B2 - Durability: ASI Clause 3.2 Timber (NZS 3602)

Framing dimensions and height are as determined by the NZS 3604 stud and top plate tables for load bearing and non load bearing walls. Kiln dried verified structural grade timber must be used. Machine stress graded timber, such as Laserframe®, is recommended.

#### Bottom plate fixing

Use GIB Handibrac® hold-down connections at each end of the bracing element. Refer to manufacturer installation instructions, supplied with the connectors, for correct installation instructions and bolt types to be used for either concrete or timber floors. Within the length of the bracing element, bottom plates are fixed in accordance with the requirements of NZS 3604.

#### Lining

One layer of Shadowclad® fixed directly to framing or over cavity battens. If part sheets are used, ensure nailing at required centres is carried out around the perimeter of each sheet or part sheet.

#### Fastening the Shadowclad®

##### Fasteners

Fasten with 60 x 3.15 mm galvanised or stainless steel flat head nails for direct fix or over cavity battens. Place fasteners no less than 7 mm from sheet edges.

##### Fasteners for H3.2 CCA treated Shadowclad

Use stainless steel fasteners where fasteners are in contact with H3.2 CCA treated timber or plywood.

Where stainless steel nails are required, annular grooved nails must be used.

Refer to table 8 of the Shadowclad Specification and Installation Guide for further fastener selection advice.

#### Fastening centres

Fasteners are placed at 150 mm centres around the perimeter of each sheet and 300 mm centres to intermediate studs. Where more than one sheet forms the brace element each sheet must be nailed off independently.

#### Fastening to cavity battens

The brace element may be fixed over cavity battens

The cavity battens must be a minimum of 40 x 20 mm nailed in staggered formation at 150 mm centres to studs around the perimeter of the brace element; and nailed to the intermediate studs within the element at 300 mm centres. 60 mm x 3.15 mm flat head galvanised or annular grooved stainless steel nails should be used.

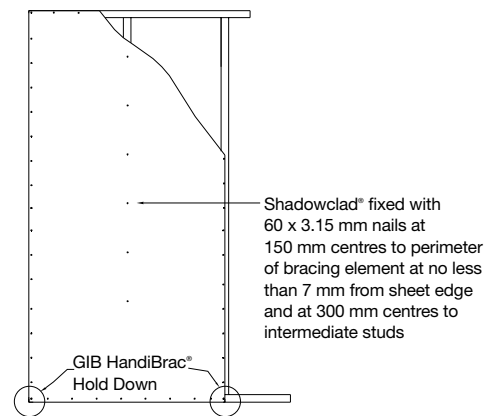

### 3.3 GIB HANDIBRAC® - RECOMMENDED INSTALLATION METHOD

Developed in conjunction with MiTek™ NZ, GIB HandiBrac® has been tested for use as a hold-down in all SC bracing elements.

- The GIB HandiBrac® registered design provides for quick and easy installation
- GIB HandiBrac® provides a flush surface for the wall linings because it is fitted inside the framing. There is no need to

check in the framing as recommended with conventional straps

- The GIB HandiBrac® is suitable for both new and retrofit construction
- The design also allows for installation and inspection at any stage prior to fitting internal linings

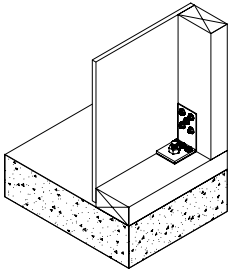
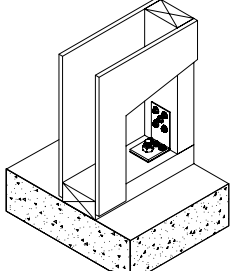
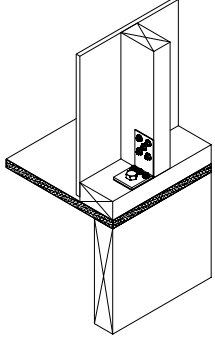
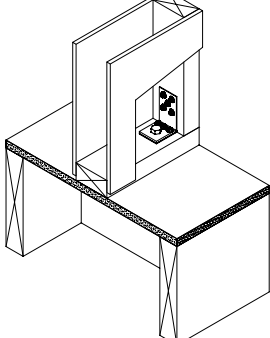
Concrete Floor		Timber Floor	
External walls	Internal walls	External walls	Internal walls
			
Position GIB HandiBrac® as close as practicable to the internal edge of the bottom plate		Position GIB HandiBrac® at the stud/plate junction	
Position GIB HandiBrac® in the centre of the perimeter joist or bearer		Position GIB HandiBrac® in the centre of the floor joist or full depth solid block	
Hold-down fastener requirements			
A mechanical fastening with a minimum characteristic uplift capacity of 15kN or screw bolt supplied with the bracket		12 x 150 mm galvanised coach screw or screw bolt supplied with the bracket	

Reproduced with the permission of Winstone Wallboards Ltd

## 4.0 INSTALLATION - INTERNAL LININGS

The use of untreated Shadowclad® is recommended for internal wall and ceiling linings where NZS 3602 allows the use of untreated plywood.

For detailed installation advice for plywood used as an internal lining refer to section 4.0 of the Ecoply® Specification and Installation Guide

## 5.0: INSTALLATION - EXTERIOR CLADDING

### 5.1 FRAMING - DURABILITY

Refer to NZ Building Code Acceptable Solution B2/AS1 "Durability". External timber framing must be treated to a minimum H1.2 treatment. For timber treatment and allowable

moisture content, refer to NZS 3602 as well as framing manufacturer's literature (e.g. Laserframe®).

### 5.2 FRAMING - CONSTRUCTION

Use kiln dried framing such as Laserframe® in accordance with timber framing manufacturer's specifications and treated in accordance with NZS 3602.

Timber frame sizes and set out must comply with NZS 3604 (or specifically designed to NZS 3603 and with stud and nog centres and timber width required by this specification.

All Shadowclad sheet edges must be fully supported by framing.

- Studs must not exceed 600 mm centres
- Nogs must be provided at a maximum of 800 mm centres

When direct fixing, position the framing to allow a 6 mm capillary gap behind panels where they overlap the edge of concrete floor, brick veneer or lower storey cladding.

- An extra stud is required at internal corners for ventilated cavities
- Refer to NZS 3602 for moisture content requirements. As a guide, frame and cavity batten moisture content should be no greater than 20%
- Framing must be kept as dry as possible at all times
- Single spans of Shadowclad should not exceed 600 mm (e.g. Below windows or balustrades)

### 5.3 PREPARATION - BUILDING UNDERLAY & RIGID AIR BARRIER

The use of building underlay compliant with E2/AS1 or an alternative solution rigid air barrier must be provided over framing prior to cladding installation

- Barriers to air flow are required regardless of direct or cavity construction
- For more information on rigid air barriers refer to the Ecoply Barrier Specification and Installation Guide
- Rigid sheathing is required in extra high wind zones and above

### 5.4 PREPARATION - DIRECT FIX CONSTRUCTION

Shadowclad can be installed either as direct fix or cavity construction.

This publication shows suggested details for cavity construction only.

Direct fix details can be downloaded from [www.chhwoodproducts.co.nz](http://www.chhwoodproducts.co.nz) or obtained by calling CHH Woodproducts on 0800 746 399.

## 5.5 PREPARATION - CAVITY CONSTRUCTION

### Cavity Construction

A Shadowclad® cavity base closure must be installed at the bottom of all walls and above window heads.

This provides vermin proofing to ventilation openings. The holes in the cavity base closure must be kept clear to enable ongoing drainage and ventilation of the cavity.

### Cavity Battens

Cavity battens provide an air space between the frame and the sheet and are considered a “packer” when installed in accordance with Acceptable Solution E2/AS1.

The battens must be fixed over the building underlay or a rigid air barrier:

All timber battens must: be nominal 20 mm thick (between limits of 18 mm and 25 mm in thickness); at least the same width as the stud; and minimum H3.1 LOSP treated in accordance with NZS 3640.

DO NOT use polystyrene battens which may melt in contact with solvents from H3.1 LOSP treated Shadowclad.

Battens must be fixed over the building underlay/rigid air barrier to all studs, as follows.

If studs are at 600 mm centres:

- Battens must be fixed at 300 mm centres vertically (i.e. a batten on studs and one in between the two studs fixed to top and bottom plates and nogs)
- Battens fixed between studs are to restrain the building underlay and insulation from bulging into the drained cavity
- The Shadowclad must not be fixed to these cavity battens where there is no framing behind them

If studs are at 400 mm centres battens must be fixed on studs only.

Horizontal battens should be used at the top of the wall to block the top of the cavity from venting into the roof space.

Cavity spacers (i.e. short pieces of cavity batten) may be used to support the bottom sheet edge (or provide intermediate support where required eg above window openings) but must allow water drainage to the outside. The cavity spacers must be fixed at a 5° minimum slope with a 50 mm minimum air gap at either side.

**SC001: Typical Framing Setout (without Battens)**

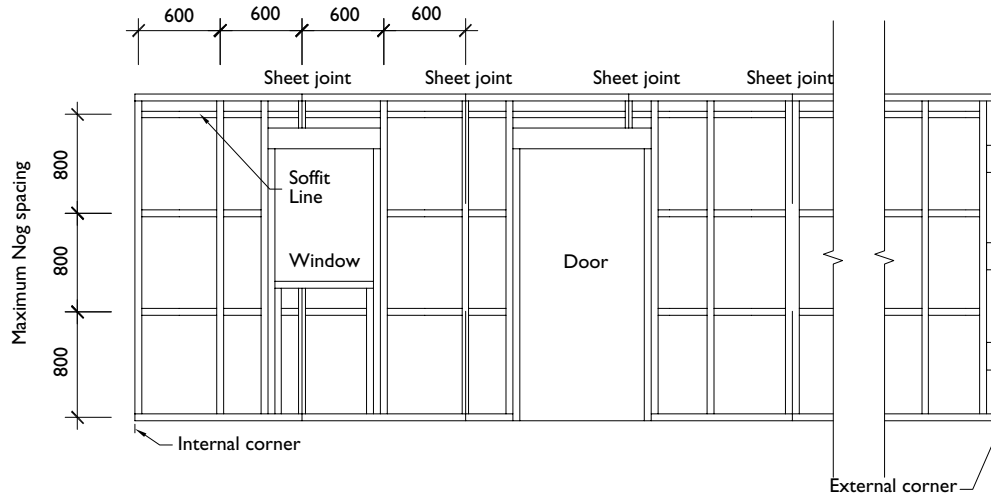

Note: Single spans of Shadowclad® should not exceed 600 mm (e.g. Below windows or on balustrades)

**SC002: Typical Framing Setout (with Battens)**

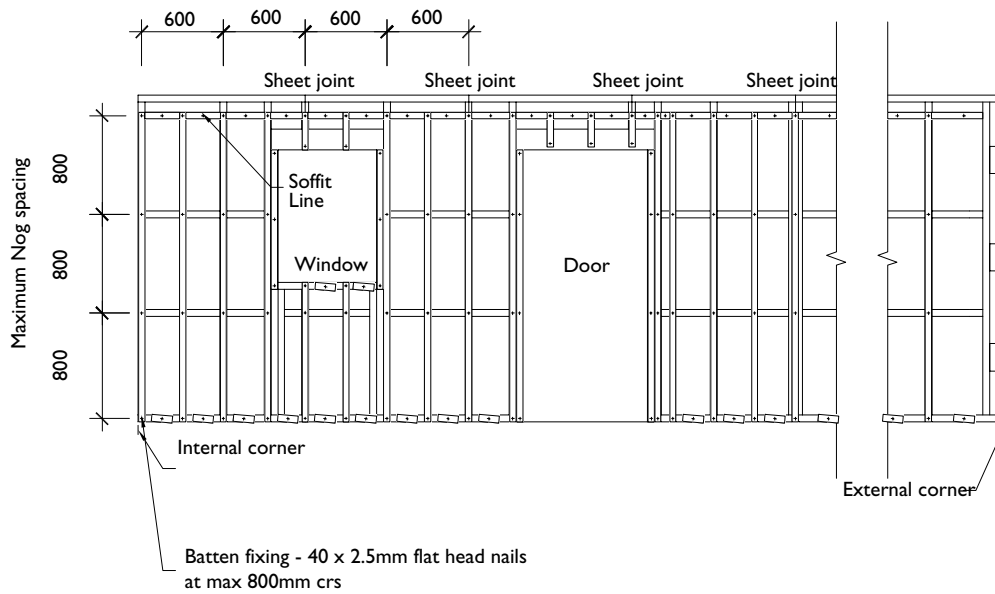

## 5.6 SHEET LAYOUT

- Sheet edges must be supported by the framing
- Sheets are designed to be vertically fixed. **Do not fix sheets horizontally**
- When laying up on to framing, start at framing corners and work across the wall
- All treated Shadowclad® panels are envelope preservative treated. Where sheets are cut, edges **must** be coated with a brush on timber preservative such as Holdfast Metalex Clear
- Cut edges should be placed at the top of the sheet to avoid rain drips soaking in to cut end grains
- Priming or pre coating of bottom edges and sheet rears to a depth of 150 mm is required for sheets which will be in close proximity to moisture such as sheets overhanging building framing close to ground and apron flashings on roofs

## 5.7 FIXINGS - FASTENER DURABILITY

TABLE 7: FASTENER DURABILITY FOR SHADOWCLAD® (INCLUDING BRACING)

Finish	Treatment	Exposure Zone (refer to section 4 of NZS 3604)	Material Required
Shadowclad Natural/Prime	H3.1 LOSP	Zones B & C	Minimum hot dipped galvanised or better
		Zone D (sea spray)	Stainless Steel
Shadowclad Prime	H3.2 CCA	All Zones	Stainless Steel

## 5.8 FIXINGS - FASTENER SIZE & LAYOUT

TABLE 8: FASTENER LENGTHS FOR SHADOWCLAD®

Application	Fastener Length (Direct Fix)		Fastener Length (Cavity Fix)	
	Cladding	Cladding & Bracing	Cladding	Cladding & Bracing
Nails in Timber	50 x 2.8 mm	60 x 3.15 mm	60 x 2.8 mm	60 x 3.15 mm
Screws in Timber	8g x 40 mm	N/A	8g x 65 mm	N/A

Shadowclad must be nailed or screwed to timber as per below:

- Use flat head (full round head) nails or rose head nails with timber framing. Rose head nails should be considered where a more decorative fastener is desired
- Standard fixing pattern: fasten sheet edges at 150 mm centres and within the panel on all supports at 300 mm centres
- When fixing over a ventilated cavity do not fix to battens that are not installed over studs as the nails will puncture the building wrap
- Fasten no closer than 7 mm to sheet edges except on edge with top lap (weather groove lap), do not nail through top lap.
- Fasten shiplap joints independently to ensure natural sheet expansion is not restricted
- When using a rigid air barrier the Shadowclad fastener lengths should be increased by the thickness of the panel to ensure required fastener pull out loadings are achieved
- Drive nails & screws flush
- Do not nail through the grooves in Shadowclad groove panels

### Fastening In Curved Applications

- Minimum radius for Shadowclad is 3600 mm along the face and 2200 mm across the face panels
- Nail sheet body as well as sheet edges at 150 mm centres

### Power Driven Fastening

- Paslode Impulse Nailers may be used to fire power driven nails. Refer to Paslode for suitable fasteners as per the minimum lengths stated in table 8
- Do not overdrive nails into the sheet
- For cladding used as bracing, fixings must be hand driven

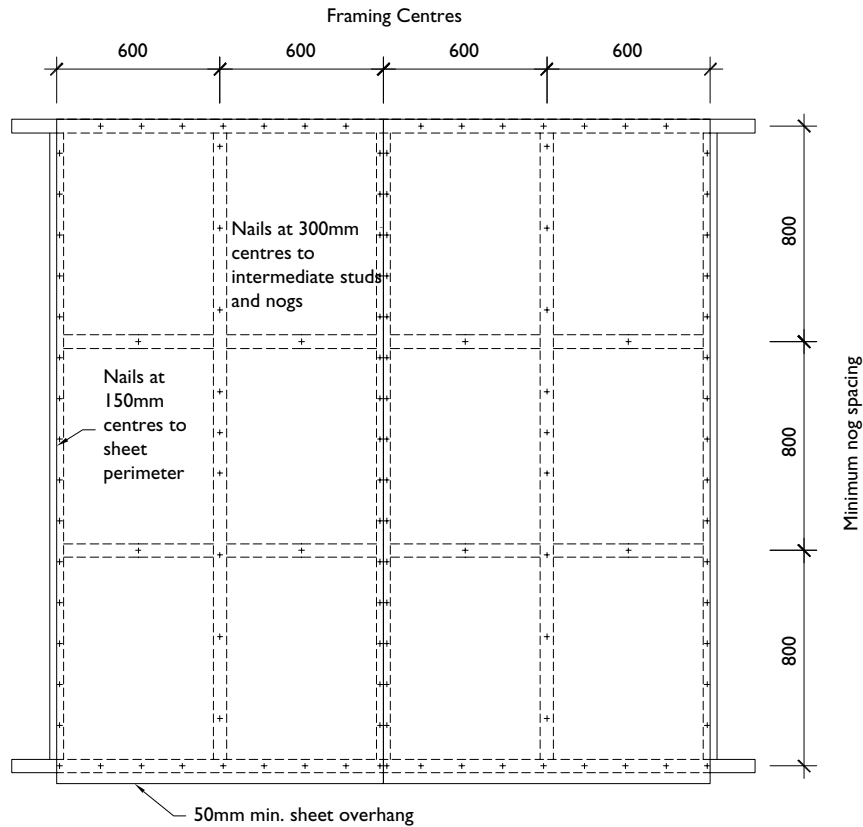
**SC003: Shadowclad® Fastener Layout****5.9 VERTICAL SHEET JOINTS**

Shadowclad® sheets have a built-in shiplap joint and weathergroove on the long edges of all sheets.

Treat all cut edges with a suitable brush on preservative treatment such as Holdfast Metalex Clear.

When installing texture groove profile sheets, use a 9 mm temporary spacer in the groove alongside shiplap joint to establish correct expansion gap.

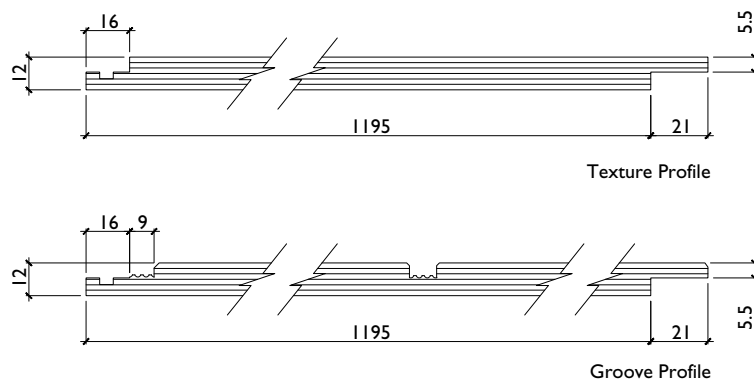
**SC004: Shadowclad® Texture and Groove Sheet Dimensions**

**SC006: Shadowclad® Texture Vertical Joint (Cavity)**

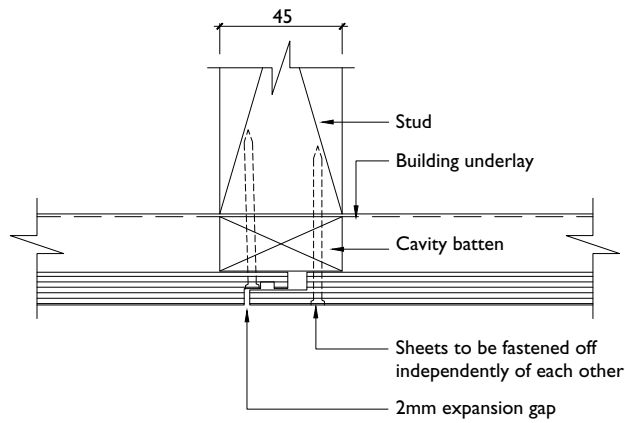

**SC008: Shadowclad® Groove Vertical Joint (Cavity)**

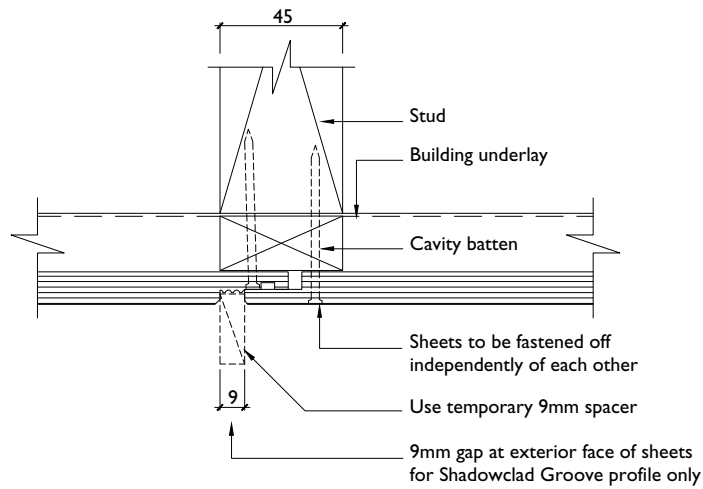

**SC010: Shadowclad® Vertical Joint with Optional Cover Batten (Cavity)**

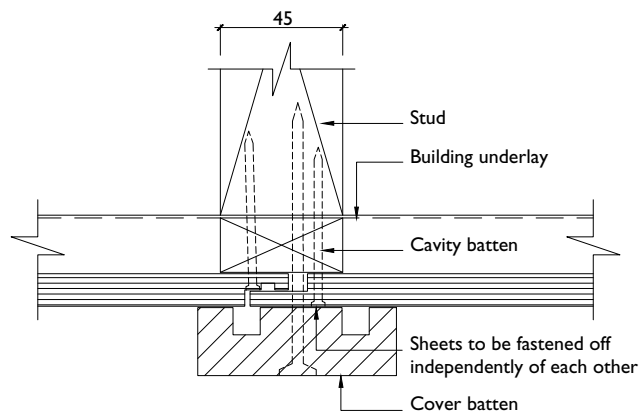

\*Direct fix details download from [www.chhwoodproducts.co.nz](http://www.chhwoodproducts.co.nz)

**SC012: Shadowclad® Vertical Joint with Cover Batten (Cavity)**

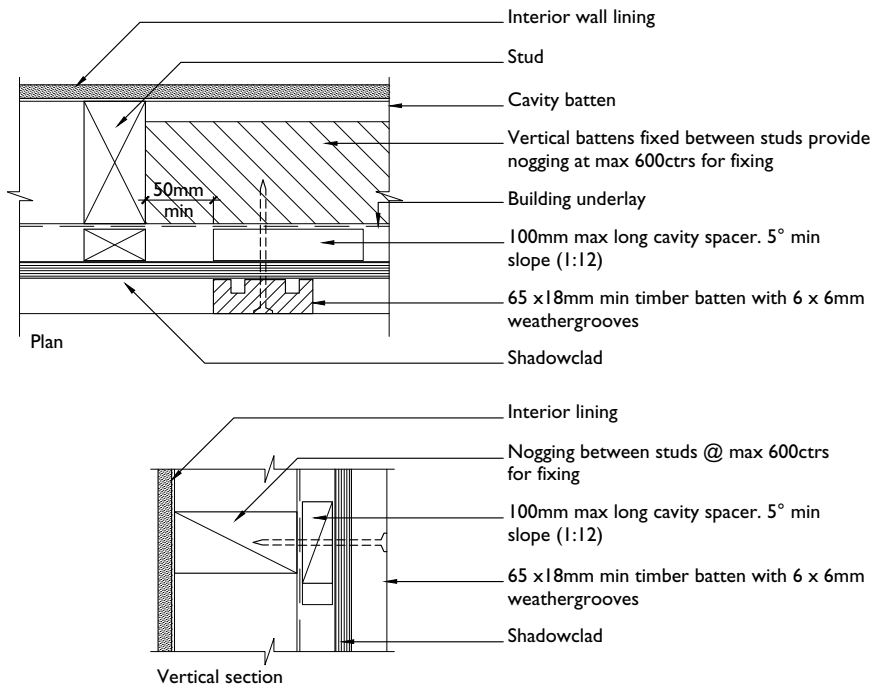

**SC014: Shadowclad® Vertical Joint with Top Hat Flashing (Cavity)**

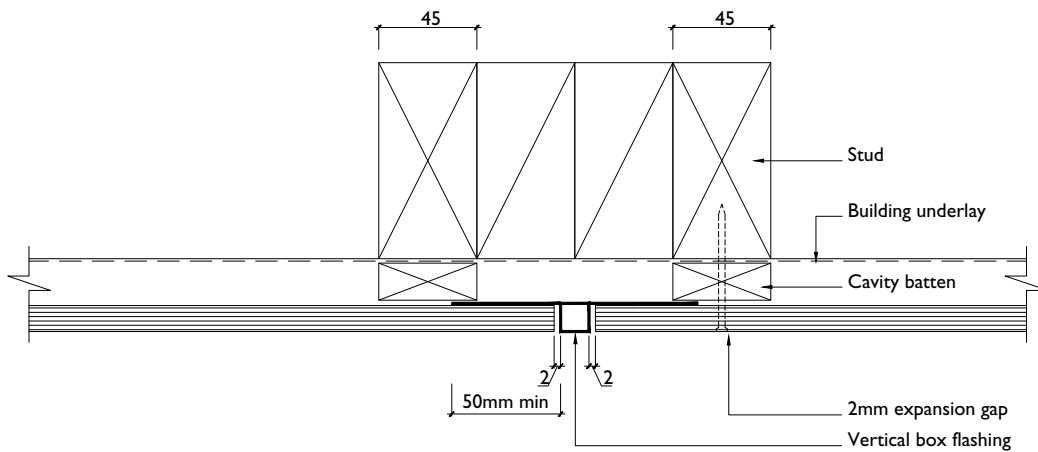

\*Direct fix details download from [www.chhwoodproducts.co.nz](http://www.chhwoodproducts.co.nz)

## 5.10 HORIZONTAL SHEET JOINTS

At floor joist level a horizontal joint must be provided to accommodate the movement resulting from timber joist shrinkage and settlement.

A Shadowclad® horizontal 'Z' flashing should be used for horizontal sheet joints.

Note: When direct fixing Shadowclad, additional building wrap is used to lap over the 'Z'-flashing upstand. Alternatively, flashing tape should be dressed over the flashing upstand.

Acceptable Solution E2/AS1 requires drained cavities to be limited to a height of two storeys.

### SC016: Shadowclad® Mid Floor Horizontal Joint (Cavity)

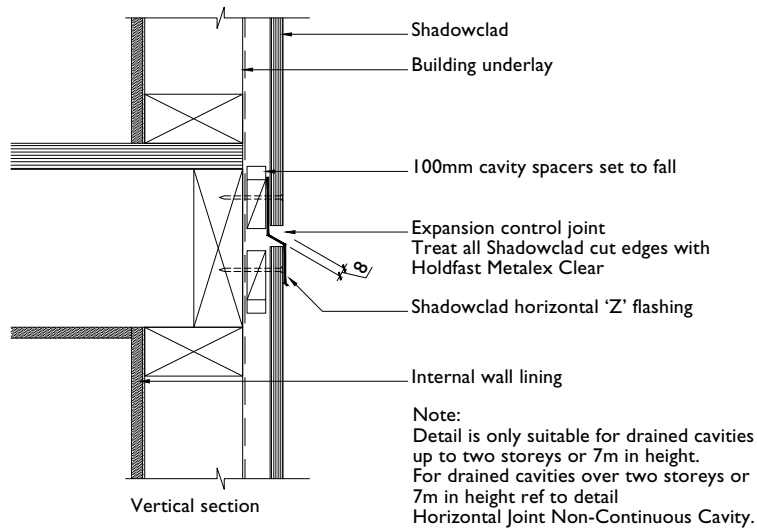

### SC018: Shadowclad® Mid Floor Horizontal Joint - Non Continuous (Cavity)

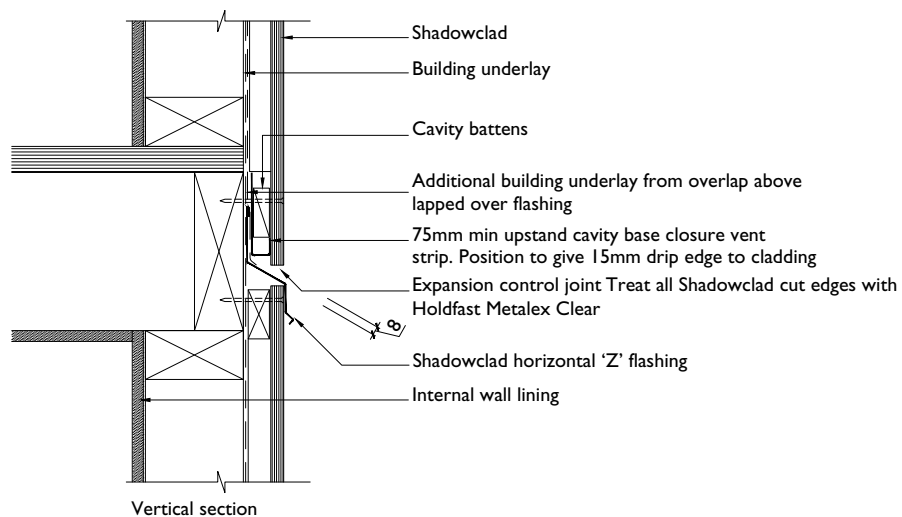

\*Direct fix details download from [www.chhwoodproducts.co.nz](http://www.chhwoodproducts.co.nz)

## 5.11 EXTERNAL CORNERS

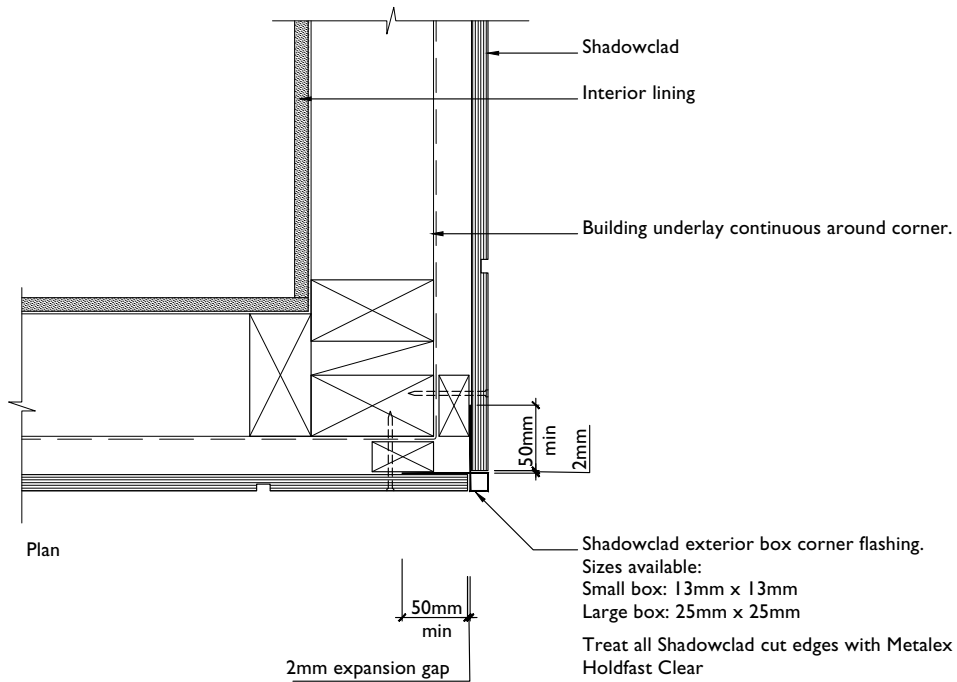
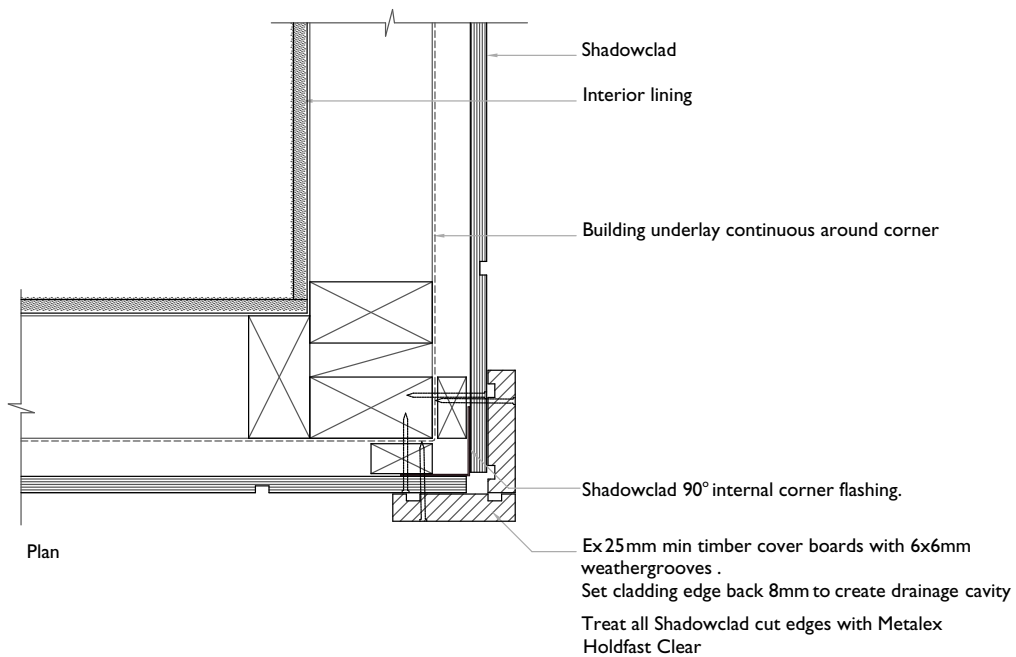
**SC020: Shadowclad® External Corner with External Box Flashing (Cavity)****SC022: Shadowclad® External Corner with Cover Boards (Cavity)**

\*Direct fix details download from [www.chhwoodproducts.co.nz](http://www.chhwoodproducts.co.nz)

## 5.12 INTERNAL CORNERS

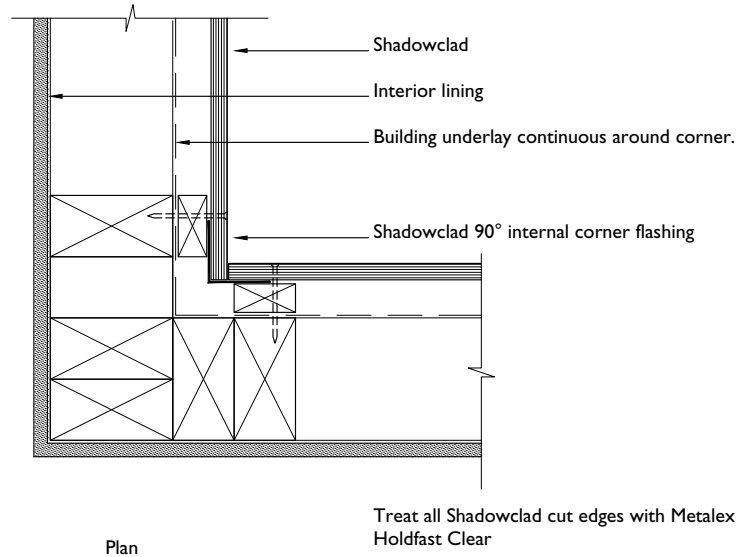
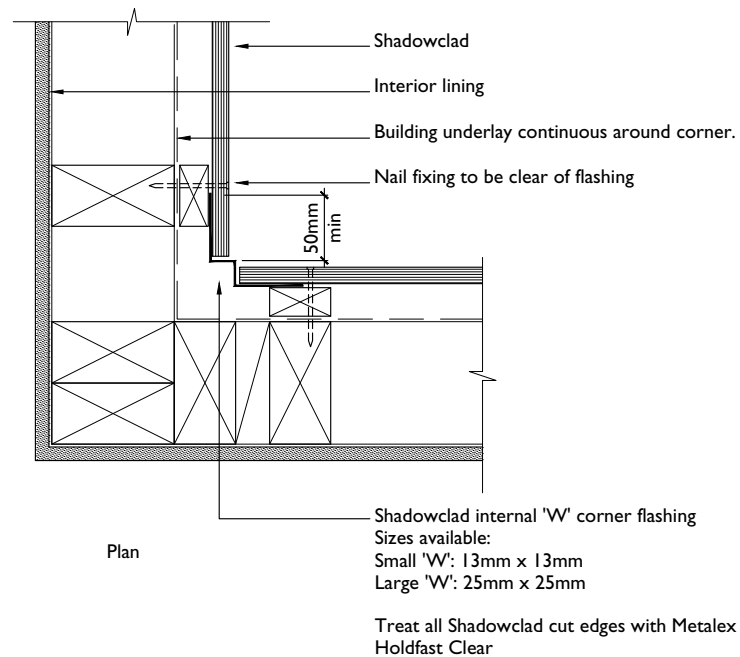
**SC024: Shadowclad® Internal Corner with 90° Flashing (Cavity)****SC026: Shadowclad® Internal Corner with W Flashing (Cavity)**

\*Direct fix details download from [www.chhwoodproducts.co.nz](http://www.chhwoodproducts.co.nz)

## 5.13 SHADOWCLAD® FLASHING JUNCTION POINTS

Flashings should have expansion joints where necessary to provide adequate allowance for thermal expansion.

- Expansion joints to be provided for joined aluminium flashings with a combined length exceeding 8 metres
- Where both ends of a flashing are constrained, allowance should be made for expansion

### Cavity Base Closure

Fix Shadowclad® cavity base closures to bottom plates through the upstand with 40 x 2.5 mm, hot dipped galvanised flat head nails at 300 mm centres.

The cavity base closure should be positioned to allow a minimum drip edge to the wall cladding of 10 mm at the base of walls, and 15 mm above window head flashings.

### Internal and External Flashings

Internal and external angles and 'Z' flashings can be nominally fixed with hot dipped galvanised flat head nails and then permanently fixed with the Shadowclad fasteners penetrating the flashing wings/upstands.

### Horizontal 'Z' Flashings

Horizontal 'Z' flashings should be butted together with a UV-resistant flexible flashing tape placed on the underside of the joint to create a weathertight joint.

Flexible flashing tapes should also be used to create weathertight joints where horizontal and vertical flashings meet.

### Shadowclad® Flashing Junctions and Connections

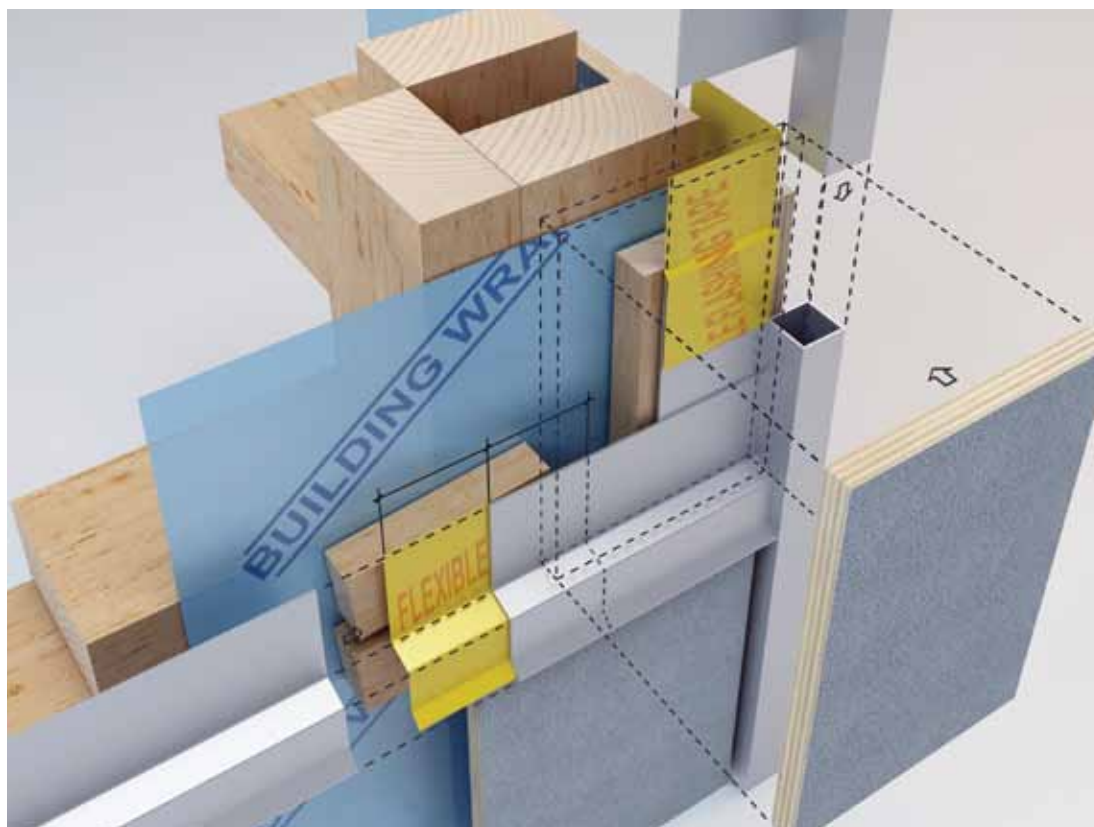

## 5.14 WINDOW PENETRATIONS

Window joinery flashings (ie head and sill flashings) should be sourced from the joinery fabricator to meet the requirements of Acceptable Solution E2/ASI or an Alternative Solution such

as the Window Association of New Zealand Window Installation System (WANZ WIS) which can be downloaded at [www.wanz.org.nz](http://www.wanz.org.nz).

### SC028: Shadowclad® Window Head Detail (Cavity)

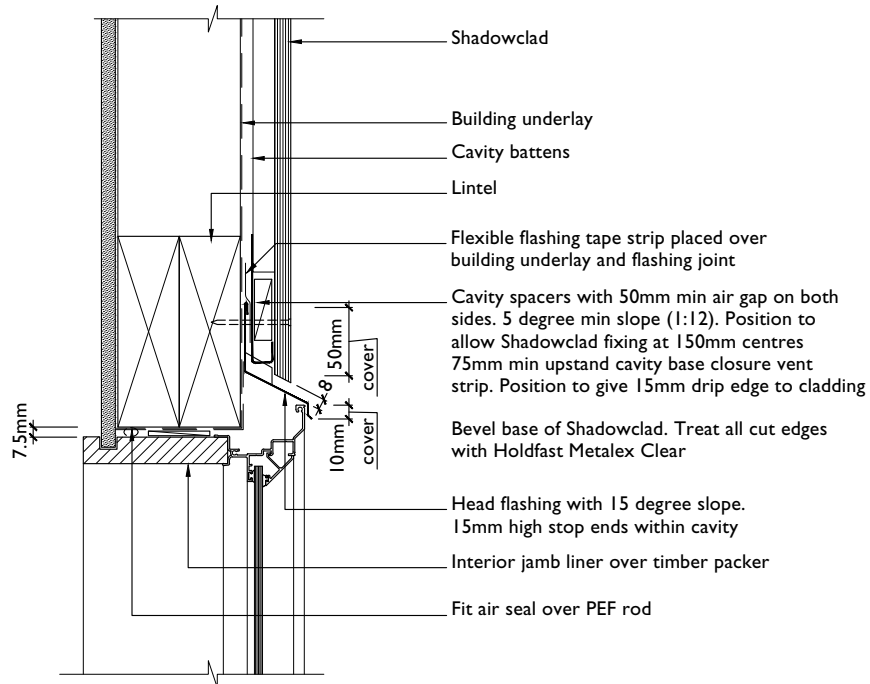

\*Direct fix details download from [www.chhwoodproducts.co.nz](http://www.chhwoodproducts.co.nz)

SC030: Shadowclad® Jamb Detail (Cavity)

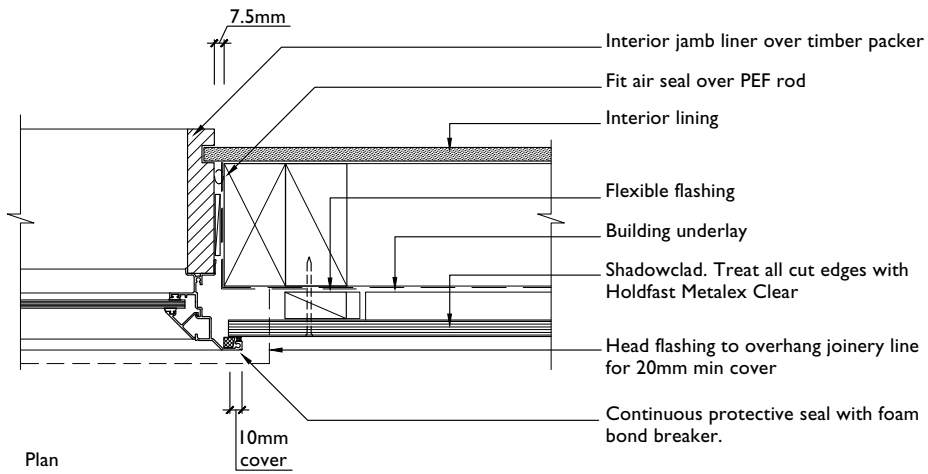

\*Direct fix details download from [www.chhwoodproducts.co.nz](http://www.chhwoodproducts.co.nz)

**SC032: Shadowclad® Window Sill Detail (Cavity)**

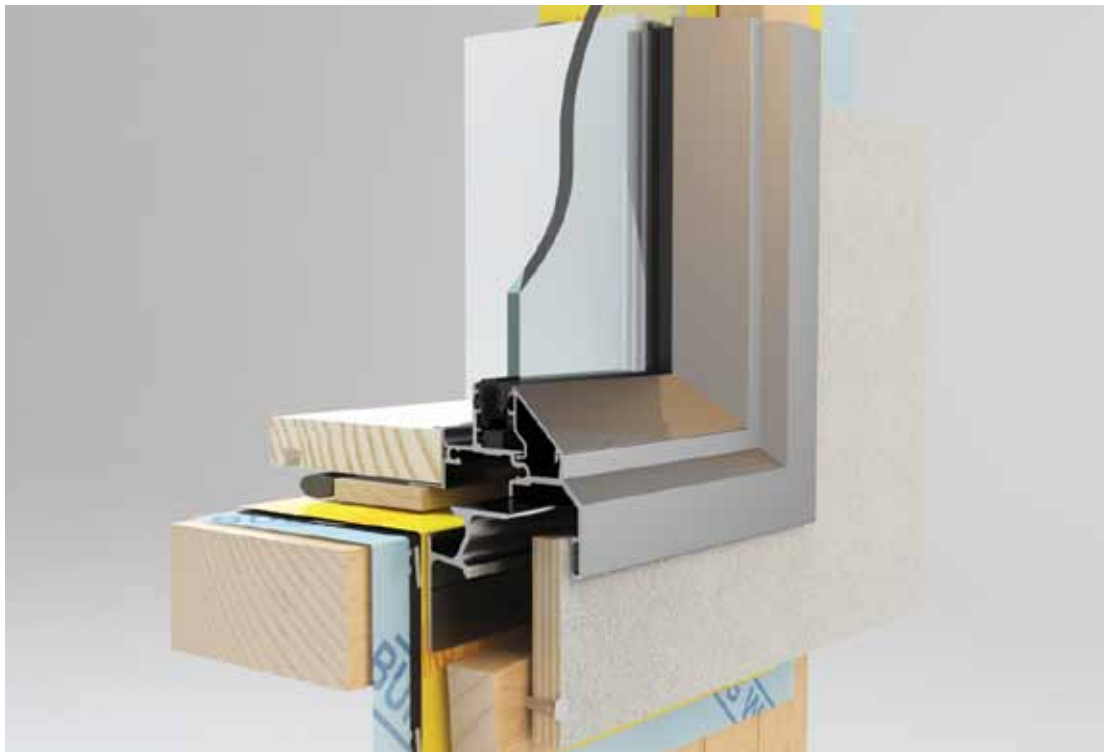
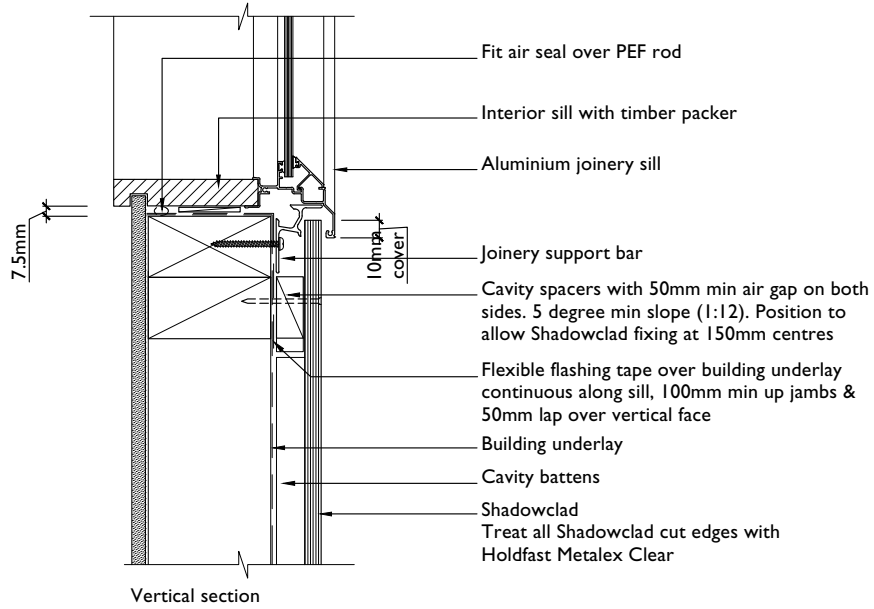

\*Direct fix details download from [www.chhwoodproducts.co.nz](http://www.chhwoodproducts.co.nz)

## 5.15 WALL PENETRATIONS

### SC034A: Shadowclad® Meterbox Side Profile (Cavity)

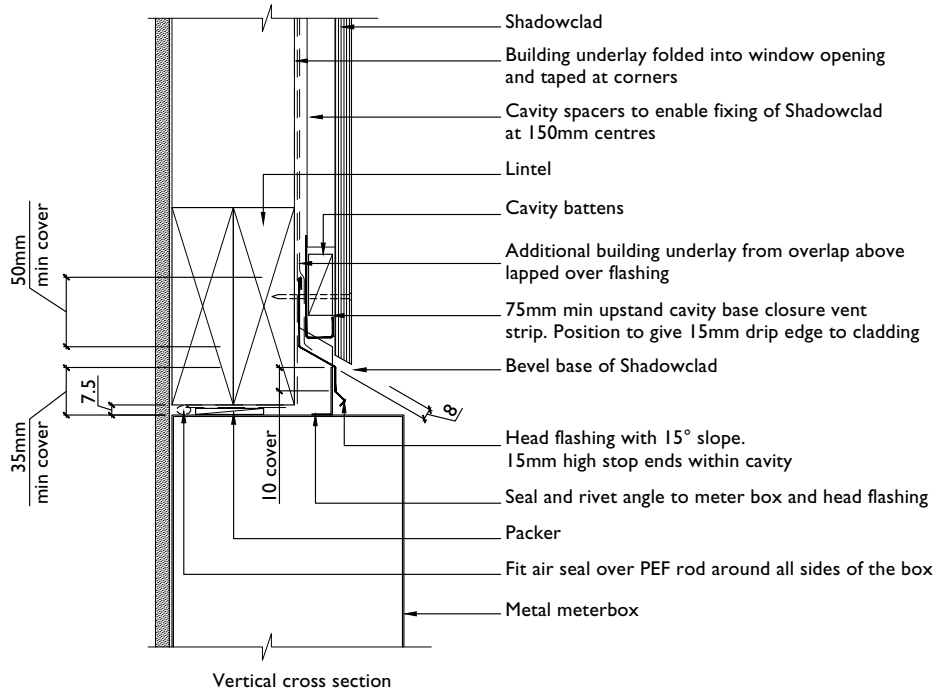

### SC034B: Shadowclad® Meterbox Top Profile (Cavity)

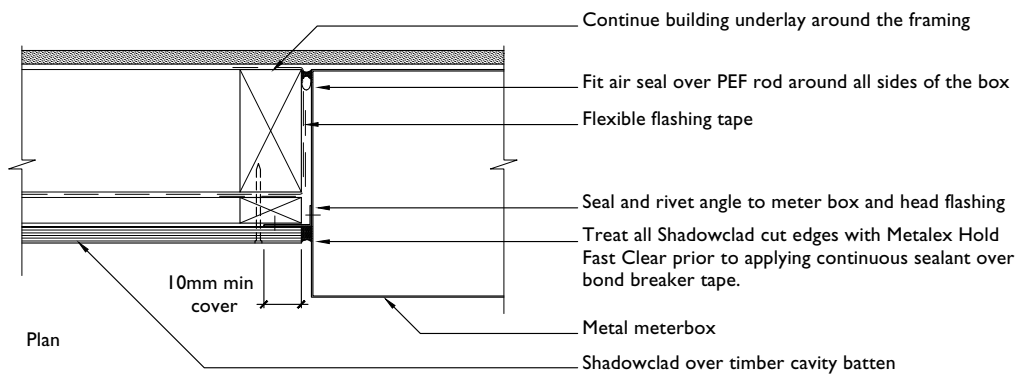

\*Direct fix details download from [www.chhwoodproducts.co.nz](http://www.chhwoodproducts.co.nz)

**SC036: Shadowclad® Soffit Detail (Cavity)**

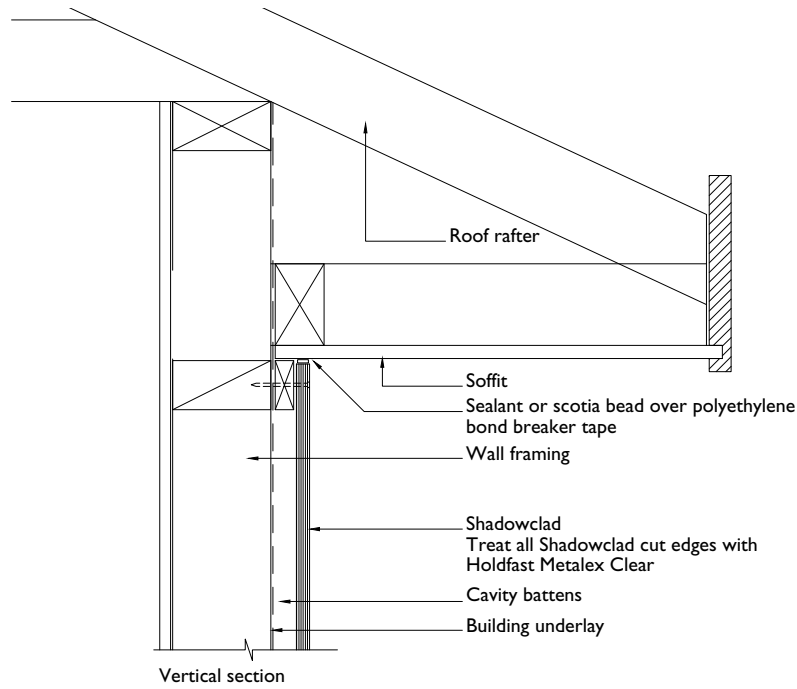

**SC038: Shadowclad® Soffit Alternative Detail (Cavity)**

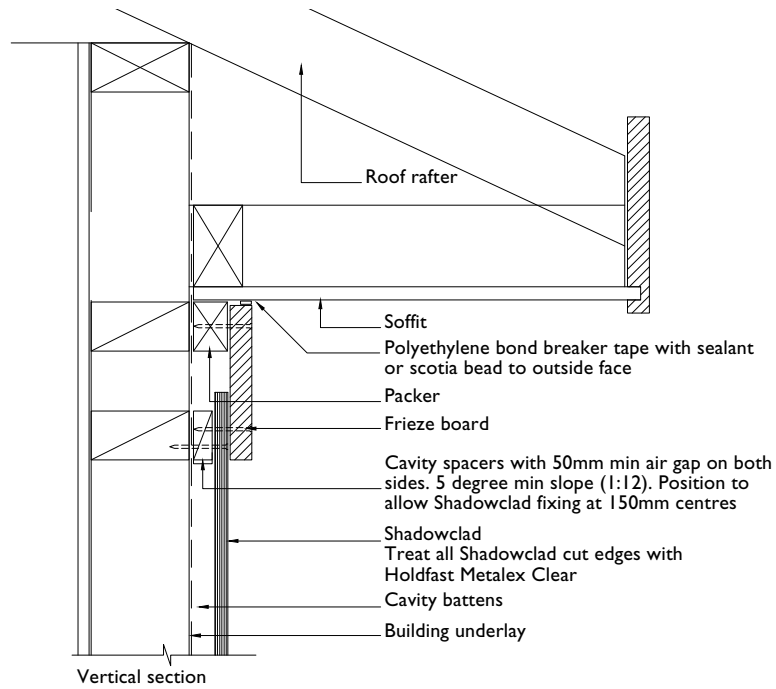

\*Direct fix details download from [www.chhwoodproducts.co.nz](http://www.chhwoodproducts.co.nz)

## SC040: Shadowclad® Pipe Penetration (Cavity)

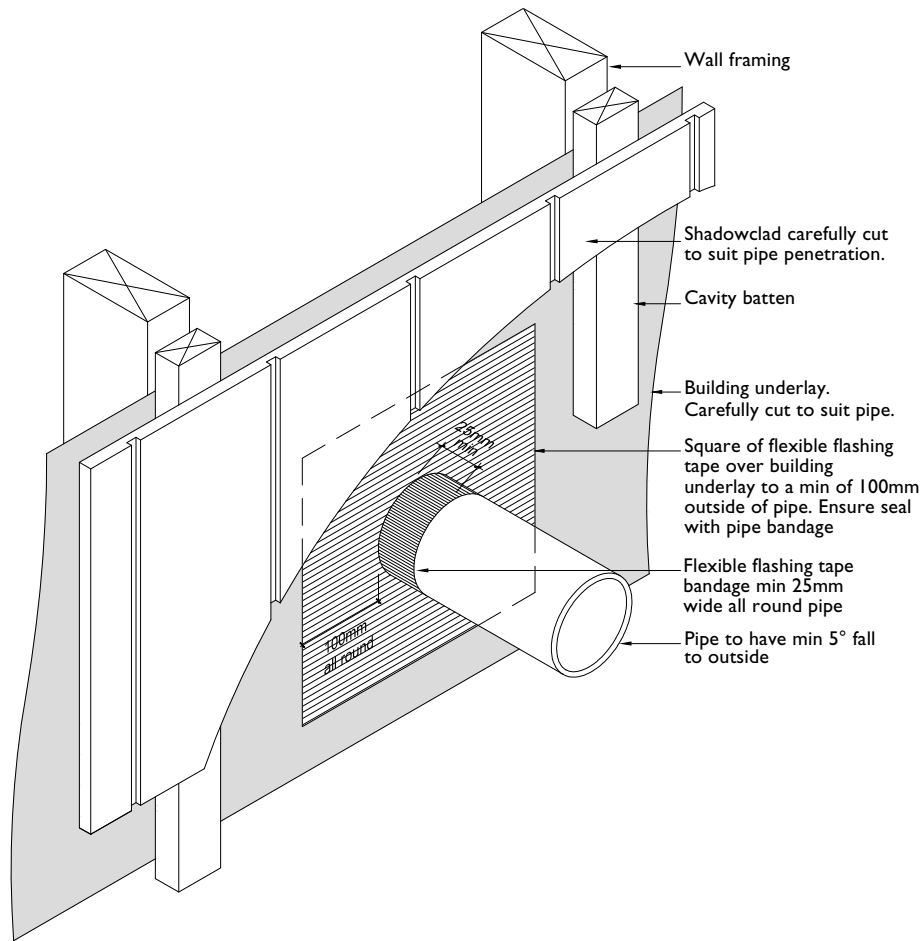

\*Direct fix details download from [www.chhwoodproducts.co.nz](http://www.chhwoodproducts.co.nz)

## 5.16 SHEET CLEARANCES

### Ground Clearances

Shadowclad® must overhang the bottom plate on a concrete slab by a minimum of 50 mm as required by NZS 3604.

The bottom edge of the Shadowclad sheet must be a minimum of 100 mm above decks or paved ground and a minimum of 175 mm above unprotected ground.

For garage door openings, refer Paragraph 9 "Openings to garages" in Acceptable Solution E2/AS1.

### SC042: Shadowclad® Overhangs and Ground Clearances (Cavity)

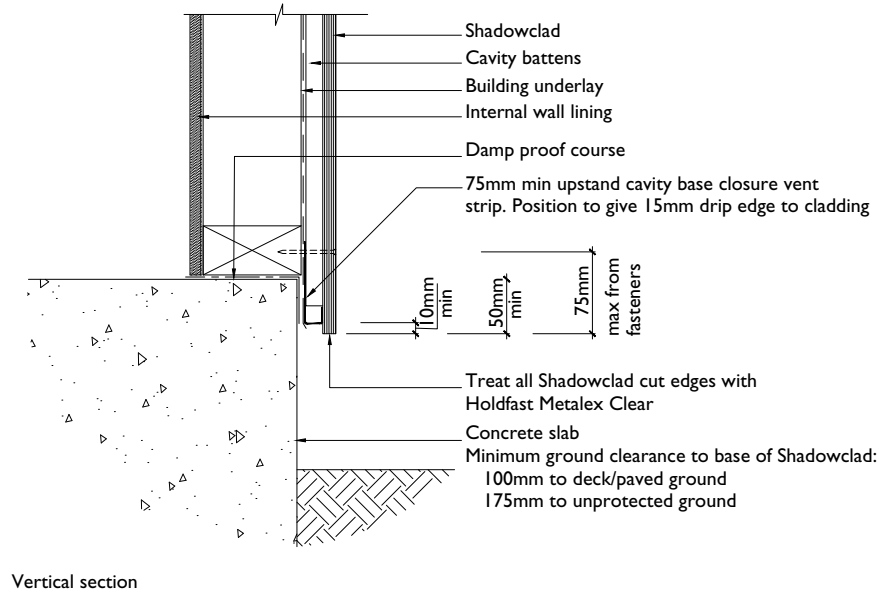

### SC044: Shadowclad® Upper Storey to Masonry Lower Storey (Cavity)

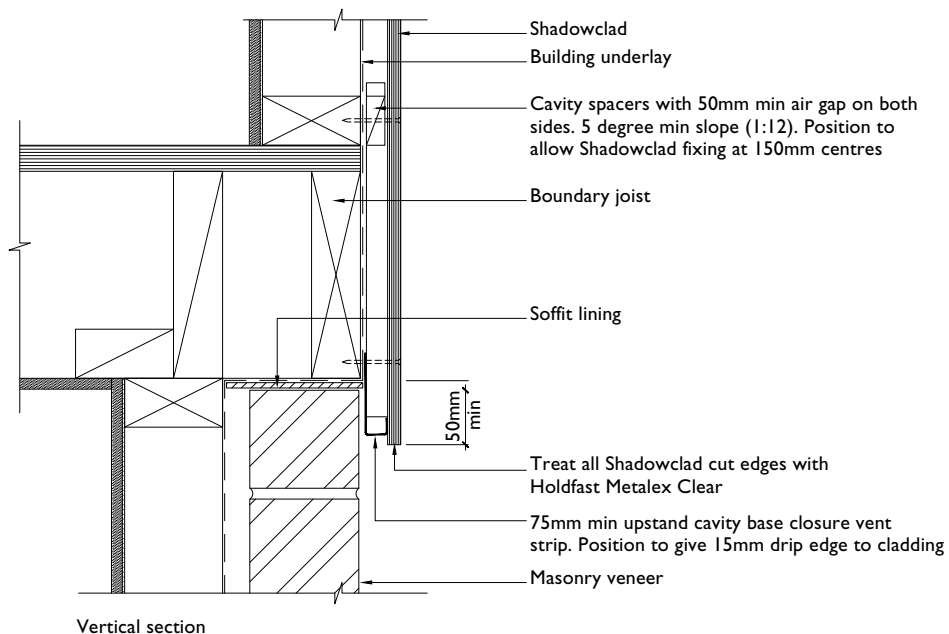

\*Direct fix details download from [www.chhwoodproducts.co.nz](http://www.chhwoodproducts.co.nz)



**SC050: Shadowclad® Basic Apron Flashing (Cavity)**

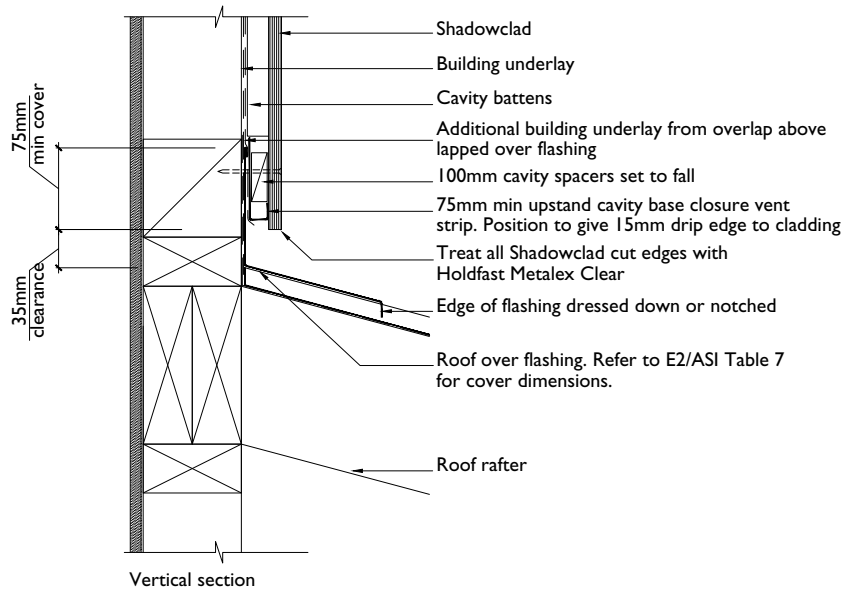

\*Direct fix details download from [www.chhwoodproducts.co.nz](http://www.chhwoodproducts.co.nz)

SC052: Shadowclad® Balustrade to Wall Junction (Cavity)

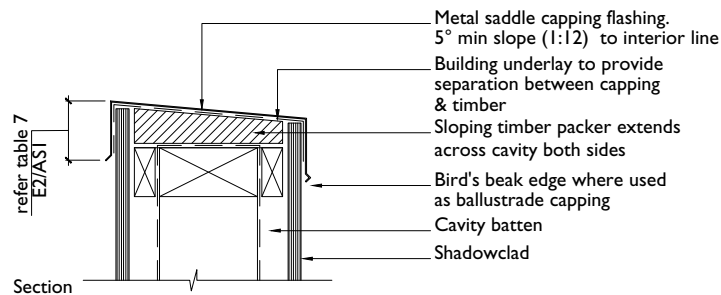
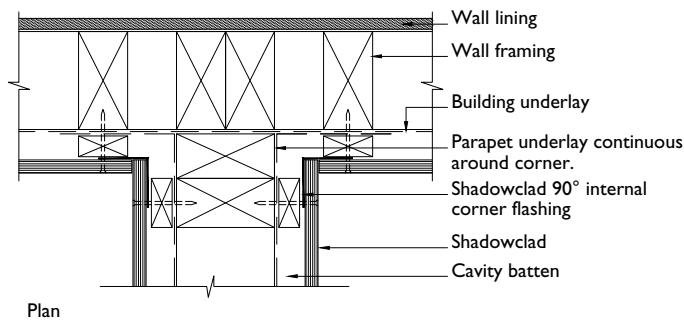
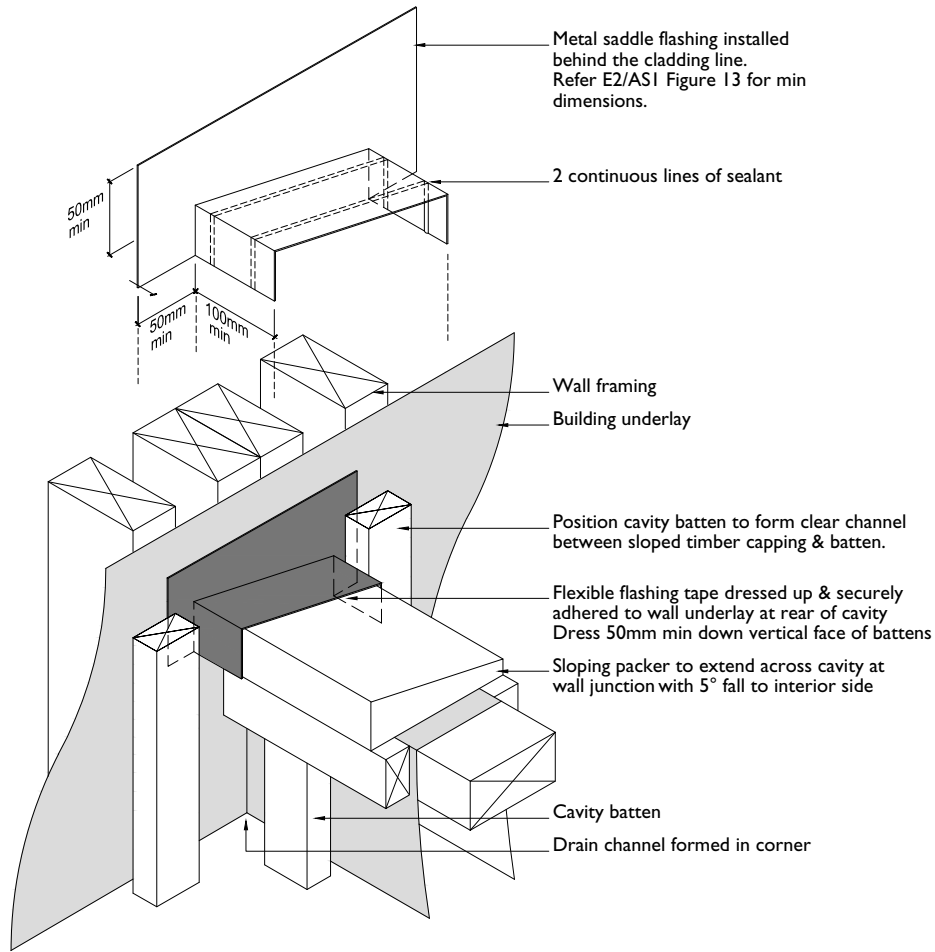

SC054: Shadowclad® Balustrade to Wall Junction (Cavity)

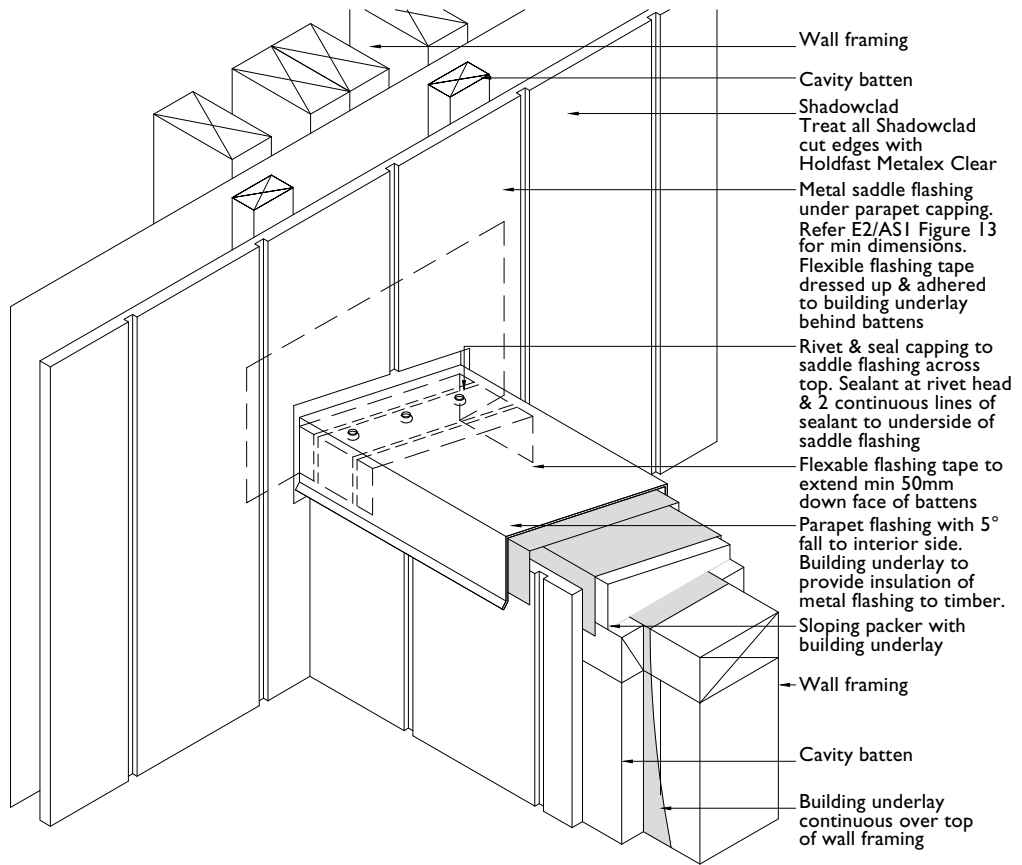

## 6.0 COATING & APPLICATION - EXTERIOR CLADDING

### 6.1 SURFACE PREPARATION

- Shadowclad® is manufactured, treated and stored in dry conditions at CHH Woodproducts manufacturing facilities. The H3 treatment provides temporary repellence to mould prior to on site coating, however it remains the applicators responsibility to ensure the surface is dry and free from dust and mould prior to coating
- If Shadowclad has been exposed to external weathering for over 3 months wash surfaces with a mild detergent solution to remove any dirt, dust, mould or sea spray prior to coating
- If recoating, remove loose, flaking or unsound coatings and wash walls prior to recoating
- The Shadowclad surface must be dry prior to applying any surface coating

### 6.2 COATING APPLICATION

- If sheets feel greasy to touch, separate and place in a dry, well ventilated area to allow any residual solvents from the treatment process to flash off prior to applying coatings
- Panels are envelope treated. Sheet cuts **must** have a brush on treatment applied such as Holdfast Metalex Clear prior to applying coatings
- Coatings should be applied by brush to ensure adequate coating film build is achieved. Application via roller or spray is not recommended
- Coating of sheet edges and on the rear of the sheet to a depth of 150 mm is considered good practice, especially in areas where the cladding is in close proximity to moisture, ground or overhangs building framing
- A minimum total coating system film build of 90 microns is recommended when painting or using film forming stains
- For detailed advice on surface preparation, coating product suitability and general coating practice always refer to the coating manufacturer prior to application

### 6.3 COATING SELECTION

The following coating information should be treated as a generic guide to coating systems typically used with Shadowclad exterior cladding. For advice on specific coating products and their suitability for use on Shadowclad always refer to the coating manufacturer.

It is important to note regardless of the cladding material selected there will always be a level of coating maintenance required to ensure the cladding material is sufficiently protected from the elements and maintains the desired appearance.

#### Paints & Film Forming Stains

The use of a good quality 100% acrylic latex paint system with a light reflectance value (LRV) of 40% or greater (i.e. light colours) which is regularly maintained will provide the highest level of protection and durability for Shadowclad and is likely to require the least amount of coating maintenance over the life of the cladding.

Dark colours (LRV of below 40%) may still be used however they are likely to increase heat and stress on the panel surface, reducing the panels overall lifespan and increasing the level of coating maintenance required to maintain an acceptable visual appearance.

Some film forming stains (i.e. coatings with the consistency of paint but with an appearance similar to penetrating stains) may offer similar protection qualities to paints however advice and assurance should be sought from the coating manufacturer as to their suitability for use with Shadowclad prior to application.

Where paints or film forming stains are to be used, the use of Shadowclad Prime is recommended. Shadowclad Prime features a factory applied primer which in most cases eliminates the use of time consuming wet primers.

Shadowclad Natural can also be used with paint however a conventional wet primer is required as part of the coating manufacturers overall system specification.

#### Penetrating Stains

Penetrating stains show the natural texture and character of timber and are widely used on Shadowclad exterior cladding.

Penetrating stains offer less protection for panels from exterior weathering than paints and film forming stains which are considerably thicker in surface film build. Due to their translucency, penetrating stains are likely to require additional coating maintenance during the panel's life to maintain an acceptable visual appearance.

Penetrating stains should only be used on Shadowclad Natural and are not recommended for use on Shadowclad Prime.

CHH Woodproducts does not recommend the use of CD50 or other lynseed oil based coating which have the potential to promote mould growth in this product.

#### Clear Coatings & Uncoated Shadowclad®

For reasons of long term aesthetics Shadowclad is not recommended to be left uncoated or clear coated for exterior cladding applications.

If left uncoated, structurally Shadowclad will meet its durability and weather tightness obligations under E2/AS1 however a high visual appearance should not be expected over the life of the cladding.

TABLE 9: COATING SYSTEM FOR SHADOWCLAD® PRIME

Within 3 months of erection	Ensure the panel is clean and dry prior to top coating. Top coat with two coats of premium 100% acrylic exterior house paint. For full top coat specifications by paint manufacturer refer to recommended paint systems chart.
Within 3 to 6 months of erection	Wash the surface with a mild detergent solution to remove any chalky material prior to top coating. Top coat with two coats of premium 100% acrylic exterior house paint. For full top coat specifications by paint manufacturer refer to recommended paint systems chart.
<p>Note: For best results</p> <ul style="list-style-type: none"> <li>i/ allow 24 hours between coats</li> <li>ii/ use a light coloured paint system, LRV above 40%</li> <li>iii/ Recommend panel be washed down prior to painting to remove any sea salt spray or dirt deposits</li> <li>iv/ Minimum total coating film build of 90 microns is recommended</li> </ul>	

## 6.4 SHADOWCLAD® COATING REQUIREMENTS IF RUN OFF IS USED FOR DRINKING WATER

Chemical manufacturers recommend that any run-off from treated surfaces should not be used for drinking water. Unsealed (eg unpainted) plywood claddings should not be used in situations where run-off directly from such claddings

is collected in water tanks for drinking water. Ensure selected coatings act as a sealer and refer to coating manufacturer's Material Safety Data Sheets to confirm specified coatings are suitable for use in these applications.

## 7.0 SHADOWCLAD® MAINTENANCE

All cladding materials including Shadowclad® will require routine product maintenance during the claddings normal service life to ensure long term durability and visual aesthetics are maintained.

### Claddings:

- Regularly wash down (yearly) with a mild detergent solution removing surface dirt, moss, mould and sea spray
- Inspect on at least a yearly basis paying particular attention to sheet joints, corners and bases
- Keep dirt, soil or leaf build-up at least 150 mm away from the base of panels
- Clean spouting and downpipes as required, so that stormwater is not overflowing onto the cladding
- Repaint as soon as the first sign of coating deterioration is identified in accordance with the coating manufacturer's specifications
- Panel recoating requirements may vary depending on climate, orientation to the sun, coating type and coating colour selected

### Flashings:

- Aluminium flashings should be periodically cleaned on a similar basis to the glass in windows
- Clean Shadowclad flashings with a diluted solution of mild liquid detergent avoiding excessively hot solutions. Use a soft bristle brush. Do NOT use abrasive tools or cleaners on the coating
- After cleaning, rinse thoroughly with fresh water. Do NOT use strong solvent type cleaners. Where the use of solvents is required, such as cleaning paint spills, use nothing other than methylated spirit. Ensure contact time is short as possible, and rinse the solvent cleaner thoroughly from the surface with copious amounts of quality drinking water
- Where cavity base closures are installed, ensure drainage holes are kept clear

## 8.0 FREQUENTLY ASKED QUESTIONS

**Q: Where can Shadowclad® be used?**

**A:** Shadowclad can be used as both exterior cladding or as an internal lining (moisture free areas only). For interior linings untreated Shadowclad should be used. For exterior cladding H3 treated Shadowclad is required.

**Q: Do I have to re-treat cut edges of Shadowclad panels?**

**A:** H3 treated Shadowclad is envelope preservative treated. All cuts made in treated plywood **must** have a brush on preservative treatment applied fully to the cut area. CHH Woodproducts recommends the use of Holdfast Metalex Clear.

**Q: When used as a cladding what are the durability expectations of Shadowclad?**

**A:** Under the NZ Building Code Shadowclad (when used as an exterior cladding) is required to meet either a 15 or 50 year minimum durability level.

**To achieve a 50 year durability Shadowclad must be:**

- H3 preservative treated
- Coated with a 3 coat (undercoat and two top coats) acrylic latex coating system such as a good quality paint of film forming stain (penetrating stains do not meet this requirement) and recoat when necessary
- Coatings must have an LRV (light reflectance value) of 40% or greater (light colours)
- Coatings must be regularly applied and maintained as part of a normal building maintenance program throughout the life of the building
- Minimum total coating system film build of 90 microns

**To achieve a 15 year durability Shadowclad must be:**

- H3 preservative treated
- Coated with a good quality penetrating stain, film forming stain or paint system
- Coatings must be regularly maintained as part of a normal building maintenance program throughout the life of the building
- Shadowclad is not recommended to be left uncoated when used as an exterior cladding

**Note** - durability according to NZ Building Code refers to the products ability to continue to perform its primary function as protection for the building structure. Appearance including the performance of the coating product is not covered under NZ Building Code durability requirements.

**Q: Can Shadowclad be used as structural bracing?**

**A:** Shadowclad can be used as structural bracing for both internal and exterior cladding applications when installed according to specifications.

Where Shadowclad is used as both exterior cladding and structural bracing a minimum 50 year durability level is required.

**Q: Can Shadowclad, when used as an exterior cladding, be coated in dark colours?**

**A:** Dark colours (coatings with an LRV of below 40%) will achieve a 15 year durability however customers must expect an increased level of recoat and general product maintenance compared to where light coating colours are used.

The greatest level of cladding protection and least amount of coating maintenance can be achieved by using a good quality paint system (applied as per the coating manufacturers specifications) with an LRV of 40% or greater and a minimum total coating system film build of 90 microns.

For further information on coatings always refer to the applicable coating manufacturer's specification material

**Q: Does Shadowclad comply with NZ Building Code Standards?**

**A:** Shadowclad has been tested in accordance with E2/VMI and NZS4284 "Testing of Building Facades" for compliance with NZ building code requirements and has been BRANZ appraised for use in both direct and cavity fix construction.

**Q: In the Shadowclad exterior flashing range can I colour the flashings to match the colour of my building?**

**A:** Shadowclad exterior flashings are available in either anodised or mill finishes. Anodised flashings are silver in colour and can be installed immediately. Mill finished flashings can be powder coated to specific colours by the customer.

## 9.0 REFERENCES AND SOURCES OF INFORMATION

- New Zealand Building Code
- AS/NZS 2269:2008 "Plywood Structural"
- AS/NZS 1604.3:2010 "Specification for Preservative Treatment, Part 3: Plywood"
- NZS 3602:2003 "Timber and Wood-Based Products for use in Buildings"
- AS/NZS 4284:2008 "Testing of Building Facades"
- NZS 3603:1993 "Timber Structures Standard"
- NZS 3604:2011 "Timber Framed Buildings"
- AS 3715:2002 "Metal Finishing – Thermoset powder coating for architectural application of aluminium and aluminium alloys"
- Acceptable Solution 'E1/AS1 – Surface Water'
- Acceptable Solution 'E2/AS1 – External Moisture'
- Acceptable Solution 'E3/AS1 – Internal Moisture'
- Acceptable Solution 'B2/AS1 – Durability'
- Ecoply® Specification and Installation Guide
- Ecoply Barrier Specification and Installation Guide
- CHH Woodproducts technical notes - downloadable from [www.chhwoodproducts.co.nz/document-library](http://www.chhwoodproducts.co.nz/document-library)
- Material Safety Data Sheet
- Window Association of New Zealand ([www.wanz.org.nz](http://www.wanz.org.nz))
- APA ([www.buildabetterhome.org](http://www.buildabetterhome.org))
- EWPA (www.ewp.asn.au)
- BRANZ appraised 764 - Shadowclad Direct Fixed Cladding System
- Branz Appraised 765 - Shadowclad Cavity Fixed Cladding System

Standards can be purchased online at [www.standards.co.nz](http://www.standards.co.nz)

Building Code Compliance Documents can be downloaded free of charge at [www.dbh.govt.nz](http://www.dbh.govt.nz)

Line drawings with this literature can be downloaded from [www.chhwoodproducts.co.nz/document-library](http://www.chhwoodproducts.co.nz/document-library)



## SHADOWCLAD® INSTALLATION CHECK LIST

## EXTERIOR CLADDING APPLICATIONS

Attention Mr Builder - the below installation areas are considered critical to the successful installation of Shadowclad® when used as an exterior cladding.

Using this sheet as an on site check list during installation will aid in problem free product installation and long term product durability post construction.

TASK	Tick when checked	
<b>Sheet Cuts</b>		
Coat all sheet cuts with a preservative timber treatment such as Holdfast Metalex Clear	<input type="checkbox"/>	
After applying Metalex apply the surface coating (e.g. paint or stain) to cut edges	<input type="checkbox"/>	
<b>Fastener Material Type</b>		
Galvanised fasteners or better used (Stainless steel annular groove nails required in sea spray zones and with H3.2 CCA treated Shadowclad Prime)	<input type="checkbox"/>	
<b>Sheet Fastener Pattern</b>		
Around sheet edge - maximum 150 mm centre spacing	<input type="checkbox"/>	
Within sheet body - maximum 300 mm centre spacing	<input type="checkbox"/>	
<b>Horizontal Sheet Joints</b>		
Minimum 8 mm separation gap between sheets above all Horizontal Z flashings	<input type="checkbox"/>	
Apply the surface coating on the sheet edge and 150 mm up the rear of the back of the sheet	<input type="checkbox"/>	
<b>Expansion Gaps Between Sheets (Vertical Sheet Joints)</b>		
Texture Profile Sheets	2 mm gap between vertical edges of sheets	<input type="checkbox"/>
Groove Profile Sheets	9 mm gap (i.e. full groove space) between vertical edges of sheets	<input type="checkbox"/>
Note: Expansion gaps required between vertical edges of sheets to accommodate natural expansion and contraction of sheets		
<b>Ground Clearances</b>		
Paved/ Sealed Ground	Minimum 100 mm distance from the ground to sheet bottom	<input type="checkbox"/>
Broken Ground	Minimum 175 mm distance from the ground to sheet bottom	<input type="checkbox"/>
Apply the surface coating on the sheet edge and 150 mm up the rear of the back of the sheet		<input type="checkbox"/>
<b>Shadowclad® Used As Structural Bracing</b>		
Panels coated with a good, quality three coat acrylic paint or film forming stain. (Penetrating stains not permitted)		<input type="checkbox"/>
Coating colour must have a light reflectance value (LRV) of 40% or more (i.e. light colours)		<input type="checkbox"/>

Refer to Shadowclad Specification and Installation Guide for full installation specifications and suggested details

# SHADOWCLAD<sup>®</sup>



As part of our ongoing commitment to the environment we have printed this brochure on FSC paper stock.



 **CarterHoltHarvey**  
Woodproducts New Zealand

Private Bag 92-106  
Auckland  
New Zealand

Freephone: 0800 746 399  
Freefax: 0800 746 400

[www.chhwoodproducts.co.nz](http://www.chhwoodproducts.co.nz)

February 2012