

Ecoply® Bracing Specification - EPG

July 2011

Structural Plywood brace with plasterboard other side

Specification No.	Minimum Wall Length	Lining Requirements	BUs/m Wind	BUs/m Earthquake
EPG	0.4 m	7mm Ecoply®, Ecoply Barrier or Shadowclad® one side and 10mm GIB® Standard plasterboard other side	100	115
	1.2 m		150	150

Framing

Wall framing must comply with:

- NZBC B1 - Structure: AS1 Clause 3 Timber (NZS3604:2011)
- NZBC B2 - Durability: AS1 Clause 3.2 Timber (NZS3602)

Framing dimensions and height are as determined by the NZS3604 stud and top plate tables for load bearing and non load bearing walls. Kiln dried verified structural grade timber must be used. Machine stress graded timber, such as Laserframe®, is recommended.

Bottom Plate Fixing

Use GIB HandiBrac® hold-down connections at each end of the bracing element. Refer to manufacturer installation instructions supplied with the connectors for correct installation instructions and bolt types to be used for either concrete or timber floors. Within the length of the bracing element, bottom plates are fixed in accordance with the requirements of NZS 3604.

Lining

- Side 1: One layer of 7mm Ecoply plywood, Ecoply Barrier or Shadowclad exterior wall cladding fixed directly to framing or over cavity battens. If part sheets are used, ensure nailing at required centres is carried out around the perimeter of each sheet or part sheet. A 2-3mm expansion gap should be left between sheets.
- Side 2: One layer of 10 or 13mm GIB® Standard plasterboard vertically or horizontally fixed. Sheet joints are touch fitted and fastener heads and joints stopped in accordance with the GIB® Site Guide.

Fastening Centres

Fasteners are placed at 150mm centres around the perimeter of each sheet and 300mm centres to intermediate studs.

Where more than one sheet forms the bracing element each sheet must be nailed off independently.

Fastening to Cavity Battens

The plywood side of the brace element may be fixed over cavity battens.

The cavity battens must be a minimum of 40 x 20mm nailed in staggered formation at 150mm centres to studs around the perimeter of the brace element, and nailed to the intermediate studs within the element at 300mm centres. A minimum of 50mm x 2.8mm flat head galvanised or annular grooved stainless steel nails must be used.

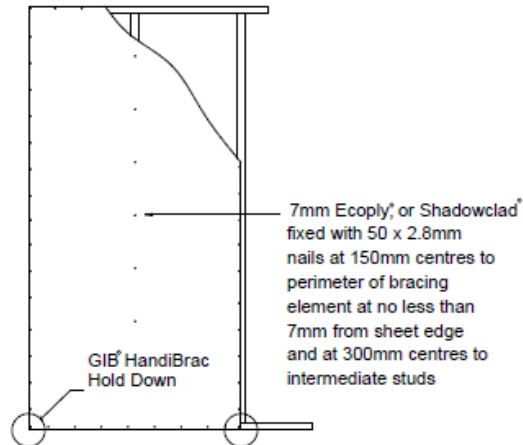

Fastening the Ecoply®

Fasteners

Fasten with 50 x 2.8mm galvanised or stainless steel flat head nails for direct fix, or 60 x 2.8mm over cavity battens. Place fasteners no less than 7mm from sheet edges.

Fasteners for H3.2 CCA treated Ecoply

Where fasteners are in contact with H3.2 CCA treated timber or plywood, fasteners shall be a minimum of hot dip galvanised

In certain circumstances stainless steel fasteners may be required. Refer to table 8 of the Ecoply Specification and Installation Guide for these circumstances and further fastener selection advice.

Stainless steel fasteners must be annular grooved.

Ecoply® Bracing Systems are designed to meet the requirements of the New Zealand Building Code and have been tested and analysed using the P21 method referenced in NZS3604:2011 listed as an acceptable solution B1/AS1 Structure. Testing was carried out using Ecoply, Shadowclad and Laserframe SGB timber framing manufactured by Carter Holt Harvey Limited trading as Carter Holt Harvey Woodproducts New Zealand, and GIB® products manufactured by Winstone Wallboards Ltd. **Substituting materials may compromise performance of the system.** GIB® and GIB HandiBrac® are registered trade marks of Fletcher Building Holdings Ltd.

Fastening the GIB® Plasterboard

Fasteners

32mm x 6g GIB® Grabber® Screws or 35mm GIB® Nails.

Fastener Centres

Fasten 50, 100, 150, 225 and 300 mm from each corner and 150mm thereafter around the perimeter of the bracing element. For vertical fixing place fasteners at 300mm centres at intermediate sheet joints. For horizontal fixing place single fasteners in the tapered edge where sheets cross studs.

Place fasteners 12mm from paper bound edges and 18mm from cut sheet edges. GIB® plasterboard must be treated in every respect in accordance with relevant GIB® literature.

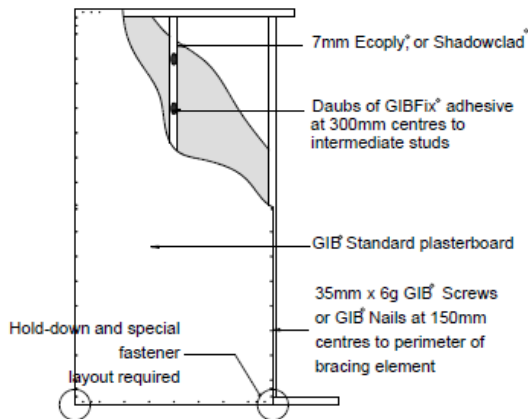

EcoPLY® Bracing Systems are designed to meet the requirements of the New Zealand Building Code and have been tested and analysed using the P21 method referenced in NZS3604:2011 listed as an acceptable solution B1/AS1 Structure. Testing was carried out using EcoPLY, Shadowclad and Laserframe SG8 timber framing manufactured by Carter Holt Harvey Limited trading as Carter Holt Harvey Woodproducts New Zealand, and GIB® products manufactured by Winstone Wallboards Ltd. **Substituting materials may compromise performance of the system.** GIB® and GIB HandiBrac® are registered trade marks of Fletcher Building Holdings Ltd.