

Specification & Installation Guide

December 2011



Contents

1.0 Ecoply Product Range.....	2
1.1 The Ecoply Brand.....	2
1.2 Product Description & Range.....	2-3
1.3 Surface Grades.....	4
1.4 Preservative Treatment.....	5
1.5 Section Properties.....	6
1.6 Product Identification.....	7
1.7 Code Compliance.....	8
1.8 General Design Considerations.....	8-9
1.9 Sustainability.....	10
1.10 Health & Safety.....	10
1.11 Storage & Handling.....	10
1.12 Limitations.....	10
2.0 General Installation Guide.....	11
2.1 Framing.....	11
2.2 Sheet Fasteners and Fixing.....	11-13
2.3 Adhesives.....	13
3.0 Structural Bracing & Ceiling Diaphragms.....	14
3.1 Design to Comply with the New Zealand Building Code.....	14-16
3.2 Ecoply Bracing Specifications Summary.....	17
3.3 Ecoply Bracing Specification - EPI.....	18
3.4 Ecoply Bracing Specification - EP2.....	19
3.5 Ecoply Bracing Specification - EPG.....	20-21
3.6 Ecoply Bracing Specification - EPGs.....	22-23
3.7 GIB HandiBrac®.....	24
3.8 Structural Ceiling Diaphragms.....	24
4.0 Internal Linings, Soffits & Appearance Plywoods.....	25
4.1 Product Range.....	25
4.2 Internal Linings & Soffits - Design Considerations.....	26
4.3 Internal Linings & Soffits - Installation.....	27
4.4 Fasteners and Fixing.....	27
4.5 Internal Linings & Soffits - Finishing.....	27
5.0 Roofs and Decks.....	28
5.1 Flexible Membrane Systems.....	28
5.2 Roof Tile Systems.....	29
5.3 Roofing and Decking - Product Selection Guide.....	29
5.4 Frame Spacings for Ecoply® Roofs and Decks.....	30
5.5 Roofing - Design Considerations.....	31-32
5.6 Roofing - Installation.....	33-34
6.0 Flooring.....	35
6.1 Flooring - Range.....	35
6.2 Flooring - Installation.....	35-36
6.3 Flooring - Finishing.....	36
8.0 Frequently Asked Questions.....	37-38
9.0 References & Sources of Information.....	39

The information contained in this manual relates specifically to Ecoply branded structural plywood manufactured by Carter Holt Harvey Woodproducts and cannot be used with any other plywood manufacturers product however similar they may appear.

Alternative plywood products can differ in a number of ways which may not be immediately obvious and substituting them for Ecoply products is not appropriate and could in extreme cases lead to premature failure and/or buildings which do not meet the requirements of the NZ Building Code.

1.0 ECOPLY® PRODUCT RANGE

Ecoply® is New Zealand's leading brand of structural plywood and is manufactured by Carter Holt Harvey® Woodproducts under a third party audited quality control programme to monitor compliance with AS/NZS 2269. As such these products carry Engineered Wood Products Association of Australasia (EWPAA) Joint Accreditation System - Australia and New Zealand (EWPAA/JAS-ANZ) certification.

For information relating to Shadowclad® and plywood used as an exterior cladding, refer to the Shadowclad Specification & Installation Guide.

1.1 THE ECOPLY® BRAND

The Ecoply brand represents a range of appearance and structurally rated plywood products which provide economy, durability, strength and design flexibility in a wide range of uses and applications.

1.2 PRODUCT DESCRIPTION AND RANGE

Ecoply structural plywood is a layered panel made from radiata pine wood veneers.

The veneers are bonded together with synthetic phenolic (PF) resin set and cured under heat and pressure in controlled conditions to form a strong and durable Type A bond. Adjacent layers (veneers) are at right angles to each other to deliver two way strength and stability. The strength of Ecoply plywood is optimised for maximum performance parallel to the face grain with cross plies providing enhanced stability across the grain.

The Ecoply plywood range can be specified for its:

- Surface grade (e.g. CD) - where the first letter describes the face veneer appearance and the second letter describes the back veneer of the Ecoply sheet. Surface grades are fully defined in AS/NZS 2269 and summarised in Table 2
- Stress grade - utilises the symbol F and a suffix e.g. F8 as a code to apply a full suite of strength and stiffness properties to plywood products of that stress grade. F8 is the standard stress grade for Ecoply products with the exception of Ecoply 19 mm Longspan Flooring and 15 mm Ecoply Roofing which are F11¹ (See Tables 1, 4 and 5). Other Ecoply products are also available in F11 upon request
- Thickness - ranging from 7 mm to 25 mm. (Thicknesses above 25 mm available subject to production capacity)
- Length - being 2400 mm and 2700 mm with a standard width of 1200 mm
- Preservative treatment - being untreated, H3.2 CCA or H3.1 LOSP Azole treated
- Edge finish - being square edge or for Ecoply Flooring, Roofing and Grooved Lining, routed on the long edges of the sheet with a polypropylene plastic tongue inserted into one side for a tongue-in-groove joint

¹ Where the stress grade F11 is referred to in all CHH Woodproducts plywood literature actual stress grade properties of panels are F11 parallel to the face grain and F8 perpendicular to the face grain

For general installation advice refer to section 2.0: General installation guide.

For specification and installation advice for Ecoply used in typical applications refer to the following sections.

Typical Application	Section
Structural bracing and ceiling diaphragms	3.0
Internal linings, soffit and appearance plywood	4.0
Roofs and decks	5.0
Flooring	6.0
Structural packaging	7.0

Note: Technical notes referenced in this publication can be downloaded from www.chhwoodproducts.co.nz or contact Carter Holt Harvey Woodproducts on 0800 326 759.

TABLE 1: ECOPLY® PRODUCT RANGE

Nominal Thickness (mm)	7		9 (3ply)		12		15		17		19		21		25	
	2400	2700	2400	2700	2400	2700	2400	2700	2400	2700	2400	2700	2400	2700	2400	2700
Sheet length (x 1200 mm width)																
BB					✓				✓							
BD			✓		✓		✓		✓							
CD	✓	✓	✓	✓	✓	✓	✓	✓	✓	✓	✓	✓	✓	✓	✓	✓
DD	✓	✓	✓	✓	✓	✓	✓	✓	✓	✓	✓	✓	✓	✓	✓	✓
Classic					✓ pt	✓ pt										
Prime					✓ pt	✓ pt										
BD												✓ pt LS				
CD												✓ pt LS	✓ pt	✓ pt	✓ pt	✓ pt
DD													✓ pt			

Available untreated only

Available either untreated or H3.1 LOSP

Available either untreated or H3.2 CCA

pt Machine grooves on both long edges with a plastic polypropylene tongue in one groove, 1200 cover
 LS Ecoply 19 mm Longspan Flooring

- Full range may not always be available ex stock, check with Ecoply supplier to ensure availability
- Non standard specifications, including thicker sheets may be available to special order in significant quantities
- All products are F8 stress grades except Ecoply 15 mm Roofing and Ecoply 19 mm Longspan Flooring which are supplied as standard in F11 stress grade¹. Other Ecoply products are also available in F11 upon request

¹ Where the stress grade F11 is referred to in all CHH Woodproducts plywood literature actual stress grade properties of panels are F11 parallel to the face grain and F8 perpendicular to the face grain

1.3 SURFACE GRADES

Table 2A summarises the surface appearance grades in which Ecoply® structural plywood is available with some typical applications for each surface grade. The surface grade

specifications are fully defined in AS/NZS 2269. Table 2B details surface appearance grades for speciality Ecoply plywood and typical applications.

TABLE 2A: ECOPLY® STRUCTURAL SQUARE EDGE PRODUCTS







Ecoply® Structural Square Edge Products		
Face Grade B	Face Grade C	Face Grade D
		
Appearance grade with a solid sanded surface. Suitable for a high quality paint, clear or stain finish.	Solid sanded surface with filled holes and splits, with intergrown knots. Suitable for a basic paint finish.	Non appearance grade allowing open imperfections up to 75 mm across the face veneer. Splits and knots allowable
Possible Uses:		
<ul style="list-style-type: none"> • Furniture/Joinery/Signs • Interior Linings • Sheathing • Engineering components where a superior visual finish is required 	<ul style="list-style-type: none"> • Structural gussets • Stressed skin panels • Bins, boxes, crates • Concrete formwork • Hoardings 	<ul style="list-style-type: none"> • Non visual bracing • Strength critical pallets • Structural components • Portal frame webs

TABLE 2B: SPECIALITY ECOPLY® PRODUCTS

Speciality Ecoply® Products		
Grooved Lining	Flooring CD	Roofing DD
		
Superior appearance smooth sanded face and 'V' grooves at 100 mm centres. Available in 2 face grades with tongue and groove on long edges: Classic - for clear stain and paint finishes Prime - pre-primed surface for paint finishes	Solid sanded C grade surface with tongue and groove profile on long edges. Features second void free layer under the face veneer for increased protection against high point loads	Unfilled D grade surface with tongue and groove profile on long edges
Possible Uses:		
<ul style="list-style-type: none"> • Internal linings • Partitions & feature walls • Semi exposed soffits - (H3.1 LOSP treated product only) 	<ul style="list-style-type: none"> • Substrate for flooring overlays such as linoleum, tiles and rigid coverings • Substrate for membrane roofing and decking where visible appearance is critical 	<ul style="list-style-type: none"> • Substrate for asphalt shingles • Substrate for roof systems where a smooth substrate is not required

Notes:

A higher visual grade may be substituted if required. e.g. Ecoply CD can be used anywhere DD is used.

Pictures shown above are scaled down versions of typical Ecoply sheets. Grain pattern, colour may vary. If sheet appearance is critical select panels individually.

1.4 PRESERVATIVE TREATMENT

Ecoply® structural plywood is available untreated or treated in accordance with AS/NZS 1604.3. If treated, Ecoply structural plywood is most often treated with either H3.2 CCA (Copper Chrome Arsenate) or H3.1 LOSP (Azole) **clear** treatment. H3.1 LOSP is the standard preservative treatment available on BB and BD Structural Square Edge and Grooved Lining products and by special request for other Ecoply products.

H3.2 CCA and H3.1 LOSP treated plywood in accordance with AS/NZS 1604.3 is described as suitable for: "outside, above ground, subject to periodic moderate wetting and leaching."

All treated plywood is envelope treated. Where sheets are cut, exposed edges **must** be coated with a suitable brush on timber preservative such as Holdfast Metalex End Seal.

The characteristics of the treatments are shown in Table 3.

TABLE 3: PRESERVATIVE TREATMENT

	Untreated	H3.2 CCA	H3.1 LOSP (Azole)
Preservative carrier	N/A	Water	Light organic oil (white spirits)
Colour	Natural	Green	Clear (i.e. natural)
Fungicide	Heat treated dry wood	Copper	Propiconazole and Tebuconazole
Insecticide	Heat treated dry wood	Arsenate	Permethrin
Other chemicals	N/A	Chrome (to fix preservative in wood)	Butyl Oxitol (co-solvent to assist active stability)
Mouldicide	N/A	Copper (limited efficacy)	IPBC
Notes	Plywood for dry interior use, supplied ex mill at <15% moisture content	Dried after treatment to average 18% moisture content for use in service at higher moisture contents	Solvent does not affect dimensions. Solvent smell disappears over time
Availability	Readily available	Standard treatment except for Ecoply BB, BD and Grooved Lining	Treated to order for CD, DD, flooring and roofing products. Standard treatment for Ecoply BB, BD and Ecoply Grooved Lining
Applications (Refer NZ3602)	Interior dry protected	Exterior/Interior damp (service performance subject to detailing & coatings)	

H3.2 CCA

Ecoply structural plywood, which is H3.2 CCA treated (waterborne preservative with a green colour), is dried following treatment so that sheets may return to the correct dimensions. The moisture content after treatment with CCA and drying will be higher than the limits placed in AS/NZS 2269 on untreated product. The target is for an average moisture content of approximately 18% to provide a panel closer to the expected equilibrium moisture content for most H3 applications.

The fillets used to separate sheets in drying may leave marks on the sheet surface. These will fade over time as the plywood weathers, and can be disguised with paint but may be visible under stain. The process of treating with CCA and subsequent drying is likely to increase the face checking of the panel. For more information on face checking refer to section 1.8 General Design Considerations - Aesthetics.

H3.1 LOSP

H3.1 LOSP treated Ecoply retains the wood colour and does not contain moisture so the plywood remains at the same dimensions and moisture content during treatment. However, the plywood when freshly treated may contain more than 60 litres of organic fluid per cubic metre. When coating H3.1 LOSP treated plywood trace amounts of residual solvent may be present on the sheet surface from the treatment process. Sheets feeling greasy to touch should be placed in a well ventilated area and allowed to flash off to ensure proper adhesion of paints and stains onto the sheet.

The H3.1 LOSP solvent smell can be quite strong and venting is recommended until most of the solvent has evaporated. Untreated plywood is recommended for internal applications where NZS 3602 allows the use of untreated plywood.

Mechanical fasteners are recommended to fix H3.1 LOSP treated Ecoply to framing. If adhesives are required, thorough venting is recommended and H3.1 LOSP tolerant adhesives should be applied according to adhesive manufacturers' instructions. See section 2.3 Adhesives.

1.5 SECTION PROPERTIES

TABLE 4A: SECTION PROPERTIES OF ECOPLY® STRUCTURAL PLYWOOD

Nominal plywood thickness ²	ID code ³	Mass	Section properties per mm width					
			Parallel to the face grain			Perpendicular to the face grain		
			Parallel Moment of Inertia	Section Modulus	Shear Constant	Perpendicular Moment of Inertia	Section Modulus	Shear Constant
(mm)		(kg/m ²)	(mm ⁴)	Z (mm ³)	I/Q (mm ²)	I (mm ⁴)	Z (mm ³)	I/Q (mm ²)
7	7-24-3	4.0	30.0	8.3	5.2	2.0	1.7	2.3
9	9-30-3	5.0	58.6	13.0	6.4	4.0	2.7	2.9
12	12-24-5	6.6	115.0	19.2	9.3	33.4	9.3	5.4
15	15-30-5	8.3	225.0	29.9	11.6	65.2	14.5	6.8
17	17-24-7	9.2	285.0	33.9	12.2	122.0	20.4	9.4
17	17-24-6	9.2	273.0	32.5	12.3	134.0	22.3	9.5
19	19-30-7	10.6	451.0	46.9	13.7	157.0	23.8	10.7
21	21-30-7	11.6	556.0	52.9	15.2	239.0	31.9	11.8
25	25-30-9	13.5	897.0	72.9	17.8	381.0	41.0	13.9

TABLE 4B: NOMINAL STRENGTHS OF SECTIONS OF ECOPLY® STRUCTURAL PLYWOOD FOR LIMIT STATES DESIGN: F8 GRADE

Nominal plywood thickness ²	ID code ³	Nominal strengths (Limit States) per mm width					
		Parallel to the face grain (F8)			Perpendicular to the face grain (F8)		
		Bending Stiffness EI	Bending Moment fZ	Rolling Shear fl/Q ⁴	Bending Stiffness EI	Bending Moment fZ	Rolling Shear fl/Q
(mm)		(1000 Nmm ²)	(Nmm)	(N)	(1000 Nmm ²)	(Nmm)	(N)
12	12-24-5	1046.5	480.0	16.7	303.9	231.7	9.8
15	15-30-5	2047.5	747.5	20.9	593.3	362.5	12.3
17	17-24-7	2593.5	847.5	22.0	1110.2	510.0	17.0
17	17-24-6	2484.3	812.5	22.1	1219.4	557.5	17.1
19	19-30-7	4104.1	1172.5	24.7	1428.7	595.0	19.2
21	21-30-7	5059.6	1322.5	27.4	2174.9	797.5	21.2
25	25-30-9	8162.7	1822.5	32.0	3467.1	1025.0	25.0

TABLE 4C: NOMINAL STRENGTHS OF SECTIONS OF ECOPLY® STRUCTURAL PLYWOOD FOR LIMIT STATES DESIGN: F11¹ GRADE (INCLUDING LONGSPAN FLOORING)

Nominal plywood thickness ²	ID code ³	Nominal strengths (Limit States) per mm width					
		Parallel to the face grain (F11)			Perpendicular to the face grain (F8)		
		Bending Stiffness EI	Bending Moment fZ	Rolling Shear fl/Q ⁴	Bending Stiffness EI	Bending Moment fZ	Rolling Shear fl/Q
(mm)		(1000 Nmm ²)	(Nmm)	(N)	(1000 Nmm ²)	(Nmm)	(N)
12	12-24-5	1207.5	595.2	18.5	303.9	231.7	9.8
15	15-30-5	2362.5	926.9	23.2	593.3	362.5	12.3
17	17-24-7	2992.5	1050.9	24.4	1110.2	510.0	17.0
17	17-24-6	2866.5	1007.5	24.6	1219.4	557.5	17.1
19	19-30-7	4735.5	1453.9	27.4	1428.7	595.0	19.3
21	21-30-7	5838.0	1639.9	30.4	2174.9	797.5	21.2
25	25-30-9	9418.5	2259.9	35.6	3467.1	1025.0	25.0

¹ Where the stress grade F11 is referred to in all CHH Woodproducts plywood literature actual stress grade properties of panels are F11 parallel to the face grain and F8 perpendicular to the face grain

² Actual thickness of Ecoply sheets manufactured to thickness tolerances stated in AS/NZS 2269

³ Identification code: panel thickness – outermost veneer thickness x 10 – number of plies

⁴ I/Q values for rolling shear are for stress at the neutral axis calculated as in NZS 3603

- Use Tables 4A & B values for all F8 stress grade Ecoply products
- Use Tables 4A & C values for all F11 stress grade Ecoply (including 19 mm Ecoply Longspan Flooring)
- The section properties in Tables 4A, B & C have been calculated in accordance with AS/NZS 2269
- For section properties for other thicknesses and Shadowclad® products contact CHH Woodproducts on 0800 326 759

Structural properties of Ecoply® plywood

The majority of Ecoply® plywood is F8 grade (exceptions are identified in section 1.2: Product description & range) and the characteristic values may be used in conjunction with both

NZS 3603 and AS 1720 for the design of timber components. The characteristic stress values in Table 5 have been used to provide nominal strengths in Tables 4B and 4C.

TABLE 5: STRUCTURAL PROPERTIES OF ECOPLY® PLYWOOD

Stress Grade	Characteristic stress value MPa	
	F8	F11
Bending (f_{pb})	25	31.0
Tension (f_{pt})	15	18.0
Panel shear (f_{ps})	4.5	5.0
Rolling shear (f_{pr})	1.8	2.0
Compression in plane of sheet (f_{pc})	20	22.0
Compression normal to the plane of the sheet (f_{pn})	9.7	12.0
Modulus of elasticity (E)	9100	10500
Modulus of rigidity (G)	455	525

Source: AS 1720.1:2011

Wood is strongest when stressed parallel to the grain and weakest across the grain, so the lay up or arrangement of veneers in the panel determines the properties. Because of its cross banded construction, plywood possesses significant strength and stiffness both parallel and perpendicular to the direction of the face grain, but is generally strongest and stiffest along the direction of the face grain.

The section properties of structural plywood in Table 4A are calculated in accordance with AS/NZS 2269 to allow for the

reduced contribution of veneers perpendicular to the direction of stress. For engineering design to NZS 3603, the section properties are multiplied by stresses and 'k' and ϕ factors to determine resistances for limit states design.

Resistances and nominal strengths in Tables 4B and 4C assume all 'k' factors are equal to 1.0. Multiply tabled values by the strength reduction factor ϕ and 'k' factors for specific in-service conditions for design to a structural code such as NZS 3603.

1.6 PRODUCT IDENTIFICATION

In accordance with AS/NZS 2269, Ecoply structural plywood sheets have the following information marked on the back:

- Brand name: e.g. ECOPLY
- Panel construction code: e.g. 15-30-5 (Thickness (mm)-Face veneer thickness (mm x 10)-Number of veneers)
- Face grade, back grade, glue bond: e.g. CD A BOND
- Intended application: e.g. STRUCTURAL
- Australasian Standard: e.g. AS/NZS 2269
- Date and time of manufacture: e.g. 16/08/07 19:45:45
- Stress grade: e.g. F8
- Formaldehyde emission class: E₀ for A Bond Ecoply
- The Engineered Wood Products Association of Australasia (EWPAA) brand and mill number: e.g. 911 (Tokoroa mill)

For example:

ECOPLY 15-30-5 CD A BOND STRUCTURAL  911
AS/NZS 2269:2008 PAT 16/08/07 19:45:45 F8 E0

If the plywood is treated, it will also be marked in accordance with the treatment standard AS/NZS 1604.3 Specification for Preservative Treatment, Part 3: Plywood.

1.7 CODE COMPLIANCE

Ecoply® plywood manufacture is third-party audited through the product quality control programme of the Engineered Wood Products Association of Australasia (EWPAA) which is itself audited by the Joint Accreditation System of Australia and New Zealand (JAS-ANZ).

CHH Woodproducts is licensed by the EWPAA to stamp plywood with the PAA/JAS-ANZ Product Certification Mark. This certifies it has been manufactured under the third party audited Joint Product Certification programme to monitor compliance with joint Australian/New Zealand Standard AS/NZS 2269 Plywood – Structural. Plywood to this standard is referenced in NZ Building Code Acceptable Solutions and Verification Methods through:

- NZS 3602 The Use of Timber and Wood-based products for Use in Building
- NZS 3603 Timber Structures
- NZS 3604 Timber Framed Buildings
- AS/NZS 1604.3 Specification for Preservative Treatment, Part 3:Plywood
- E2/AS1 External Moisture



WARNING: Plywood which is non-certified or is manufactured to standards other than AS/NZS 2269, such as US voluntary standard PSI-95, is not referenced in the NZ Building Code. There can be significant differences between AS/NZS 2269 certified and non certified plywood around bond durability, structural ratings and veneer quality.

Structure B1

Design to NZS 3603 Timber Structures complies with the NZ Building Code in Verification Method B1/VMI clause 6.0 Timber, Structural. Plywood is the only sheet material with properties listed in NZS 3603. Ecoply structural plywood is available in F8 stress grade with some specialty products available F11 or with specifically designed properties for specialised applications.

1.8 GENERAL DESIGN CONSIDERATIONS

Durability and exterior moisture E2

Ecoply plywood is made from softwood solid radiata pine veneer. Designers should assess the level of exposure to biological, moisture, and other hazards and apply appropriate preservative treatment and detailing to minimise exposure to these hazards.

Information in this manual outlines suggested practices for detailing building components to exclude moisture to comply with the durability requirements of the NZ Building Code.

Formaldehyde

Ecoply plywood is manufactured using phenol formaldehyde resins which are fully cured in the hot press. Cured resin is thermally and moisture stable and formaldehyde emissions for the glued plywood are similar to background levels for the wood by itself when tested to AS/NZS 2098.11 Determination of formaldehyde emissions for plywood. Accordingly every panel is branded with the lowest emission class (less than 0.5 mg/litre for E₀).

Actual formaldehyde emissions for Ecoply plywood have been tested and approved as having an actual formaldehyde emission level of less than 0.3 mg/ litre (equivalent to a Super E₀ emission level).

Moisture content and dimensional change

At the time of leaving the factory, the moisture content of untreated Ecoply plywood should generally be in the range of 8% to 15% as required by AS/NZS 2269. All wood products including plywood respond to changes in ambient humidity so the eventual moisture content of plywood varies according to how dry or how wet the environment is. After manufacture, the moisture content will move to equilibrium with the environment, and the veneers swell or shrink across the grain in response. The total expansion both along and across a 2400 x 1200 mm panel can be in the order of 1.5 mm to 3 mm as the plywood changes from a dry to a saturated state.

Ecoply that is treated with waterborne preservatives (e.g. H3.2 CCA) is expected to be used in applications that have higher humidity than interior dry use, so following treatment it is dried to a higher average moisture content of approximately 18%. This provides for a more stable panel in service than placing a dry (less than 15%) sheet in a higher moisture environment.

Detailing and construction must allow for movement if the plywood will be subject to cycles of moisture change. Seasonal and daily cycles can be significant depending on the end use.

Temperature

Wood will expand upon heating as do practically all solids. The thermal expansion of plywood is quite small and there is little effect on the structural performance or durability of plywood when used in temperatures below 54°C. The average co-efficient of thermal expansion of plywood is 4.5×10^{-6} mm/mm/°C. At temperatures above 55°C wood begins to deteriorate. Colours of coatings and finishes should be selected to reduce heat gain. For extreme conditions, further technical information is available by calling CHH Woodproducts on 0800 326 759.

The thermal resistance or insulating effectiveness of plywood panels can be calculated using NZS 4214. e.g. Plywood has a Conductivity (k) of 0.13 W/mK so a 12 mm panel has a thermal resistance $R = 0.012/0.13 = 0.09$.

Aesthetics

Ecoply® plywood products can be selected for decorative or weather protection functions as well as structural performance.

Acceptable Solution E2/AS1 External Moisture allows plywood manufactured to AS/NZS 2269, (minimum CD appearance grade, minimum 12 mm thickness and treated as required by NZS 3602) to be used for exterior cladding. For exterior cladding applications CHH Woodproducts strongly recommends Shadowclad® exterior cladding over smooth faced plywood such as Ecoply.

Shadowclad features a bandsawn face to help reduce the incidence and appearance of face checking and other appearance related issues which can occur on smooth faced plywood if not regularly maintained by the homeowner. For more information on plywood used as an exterior cladding refer to the Shadowclad Specification and Installation Guide.

Face checks on plywood exposed to weather

- Face checks (lengthwise separations of the wood fibre occurring in the face veneer) are the result of normal expansion and contraction of the wood fibre as it gains and loses moisture from the external environment
- Face checks occur naturally in all wood based products and their extent in plywood can vary depending on the length of exterior exposure, climate conditions and protection offered by the surface coating

- Face checks in plywood do not affect the structural integrity of the panel as they are confined to the surface veneer and are strictly aesthetic in nature
- As face checks occur naturally CHH Woodproducts does not consider them to be a manufacturing or product fault

Durability

The durability of Ecoply structural plywood will depend on the application. Detailing, treatment and installation details need careful consideration to satisfy the requirements of the NZ Building Code.

Normally, 50 year durability can be achieved with untreated Ecoply in dry, interior exposure. For internal environments subject to high humidity or condensation H3 treated Ecoply should be used.

Unpainted H3 treated Ecoply in exterior applications (excluding plywood used as cladding) will weather and oxidise but panels can be expected to perform structurally for 15 years. However the lack of protection will lead to appearance related issues such as surface checking, mould growth and discolouration of the sheet surface which are not considered manufacturing faults by CHH Woodproducts.

Where plywood is used as cladding (including cladding acting as bracing) refer to the Shadowclad Specification and Installation Guide.

For plywood as a rigid air barrier (including rigid air barrier acting as bracing) refer to the Ecoply Barrier Specification and Installation Guide.

Fire, spread of flame and smoke development

The following data on early fire hazard properties of uncoated Ecoply plywood are the result of tests carried out by Applied Physics Laboratory and are similar to results from extensive testing done in Australian Laboratories on uncoated radiata pine plywood.

For plywood with decorative finish coatings or intumescent coating, performances depend on spread rates of the coating. Advice and coating specifications should be sought from the coating manufacturer.

TABLE 6: EARLY FIRE HAZARD PROPERTIES OF 12 MM ECOPLY® PLYWOOD

	Ignitability Index (Ig)	Spread of Flame Index (SFI)	Heat Evolved Index (HEI)	Smoke Developed Index (SDI)
Ecoply® Structural Plywood, Untreated, Uncoated	14	7	7	3
Ecoply® Structural Plywood H3.2 CCA Treated	14	6	4	3

1.9 SUSTAINABILITY

Ecoply® is manufactured from radiata pine, a plantation grown medium density softwood. It is grown on tree farms which are tended and harvested to provide wood for plywood manufacture. The crop is managed on a sustainable basis to yield millable trees.

New Zealand plantations are managed in compliance with the New Zealand Forest Accord.

Ecoply is manufactured in New Zealand at CHH Woodproducts Tokoroa plywood mill.

Ecoply is available Forestry Stewardship Council (FSC) (SCS-COC-001316) certified upon request.

1.10 HEALTH & SAFETY

Ecoply should be handled in accordance with the Material Safety Data Sheets (MSDS) for untreated, H3.2 CCA and H3.1 LOSP treated Ecoply, which are available upon request.

Always wear safety glasses or non-fogging goggles when machining Ecoply panels.

If wood dust exposures are not controlled when machining (sawing, routing, planing, drilling etc) a class P1 or P2 replaceable filter or disposable face piece respirator should be worn.

Wear comfortable work gloves to avoid skin irritation and the risk of splinters. Wash hands with mild soap and water after handling panels.

1.11 STORAGE & HANDLING

Ecoply requires care in storage and handling. The following suggestions will help keep the plywood in good condition before use and after installation:

- The storage area should be protected from sun, rain and wind that would otherwise bring about rapid changes in temperature and humidity
- Support for the sheets should be provided at both ends and middle to avoid distortion. Ensure bearers in packs above are aligned over bearers below (to avoid inducing curves in sheets)

- The stack should be kept dry and clear of ground contact, and placed so that it will not be exposed to mechanical damage
- The sheets should be stacked flat, NOT on edge
- To avoid staining, fading and surface checking, the sheets should not be exposed to the weather while awaiting installation

1.12 LIMITATIONS

The information contained in this document is current as at December 2011 and is based on data available to CHH Woodproducts at the time of going to print.

This publication replaces all previous CHH Woodproducts design information and literature relating to Ecoply Structural, Ecoply Bracing, Ecoply Flooring, Ecoply Roofing & Decking and Origin® plywood. CHH Woodproducts reserves the right to change the information contained in this document without prior notice. It is important that you call 0800 326 759 to confirm that you have the most up to date information available or refer to www.chhwoodproducts.co.nz

This publication is a guide only and is not intended to be used as a substitute for NZ Building Code requirements and associated standards.

CHH Woodproducts has used its reasonable endeavours to ensure the accuracy and reliability of the information contained in this document and, to the extent permitted by law, will not be liable for any inaccuracies, omissions or errors in this information nor for any actions taken in reliance on this information.

2.0 GENERAL INSTALLATION GUIDE

The following is a general guide to be followed unless otherwise specified. For additional installation instructions for typical

applications refer to section 3.0: Typical applications.

2.1 FRAMING

Use kiln dried framing e.g. Laserframe® in accordance with timber framing manufacturers' specifications and treated in accordance with NZS 3602. All timber frame sizes and set out must comply with NZS 3604 (or be specifically designed to NZS 3603). Ecoply® may be specified for frame spacing determined by design, or using tables in section 3 for specific product applications such as bracing, internal linings, flooring and as a substrate for shingle roofs or membrane roofs and decks.

H3.1 LOSP treated framing should be vented before fixing and if construction adhesives are required (for example to screw and glue floor panels) the adhesive must be compatible with H3.1 LOSP. See section 1.4: Preservative treatment.

For plywood used as exterior cladding refer to the Shadowclad® Specification & Installation Guide.

2.2 SHEET FASTENERS AND FIXING

- Where there is risk of panel size change due to changes in moisture levels, allow a 2 to 3 mm expansion gap between sheets
- Use only flathead nails or screws, with or without construction adhesives
- Fastener length should penetrate at least 10 nail diameters into the framing or be three times the sheet thickness, whichever is the greater. Longer or ring shank nails may be specified
- Fasteners must be at least 3 fastener diameters or 7 mm from the edge of the sheet. Because of its cross banded construction, fasteners can be placed close to the edge of the sheet to allow joining on narrow framing members
- For tongue and groove products such as flooring and roofing fasten 15 mm from tongue and groove edges
- Standard fixing pattern: unless otherwise specified fasten edges and ends of sheets at 150 mm centres, and within the panel at no more than 300 mm centres (see diagram below)
- Use hot dipped galvanised fasteners or corrosion resistant fasteners (i.e. stainless steel) determined by design for specific hazards
- Where using stainless steel nails, nails must be annular grooved
- Refer to Table 7 for minimum fastener sizes
- Do not over-drive power driven nails

EC001: Fastener spacings for Ecoply®

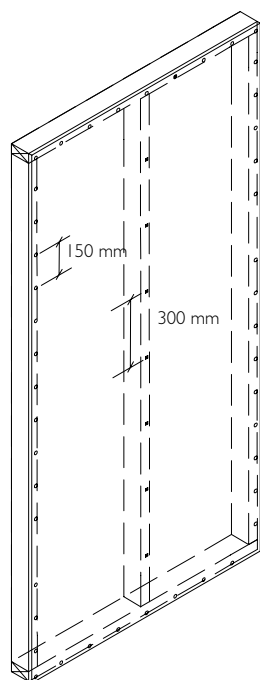

Ecoply® fastened in vertical plane

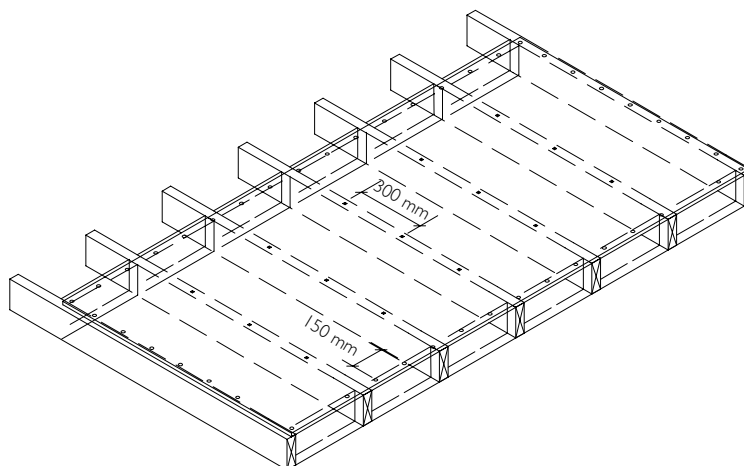

Ecoply® fastened in horizontal plane

EC002: Fastener spacings from edges

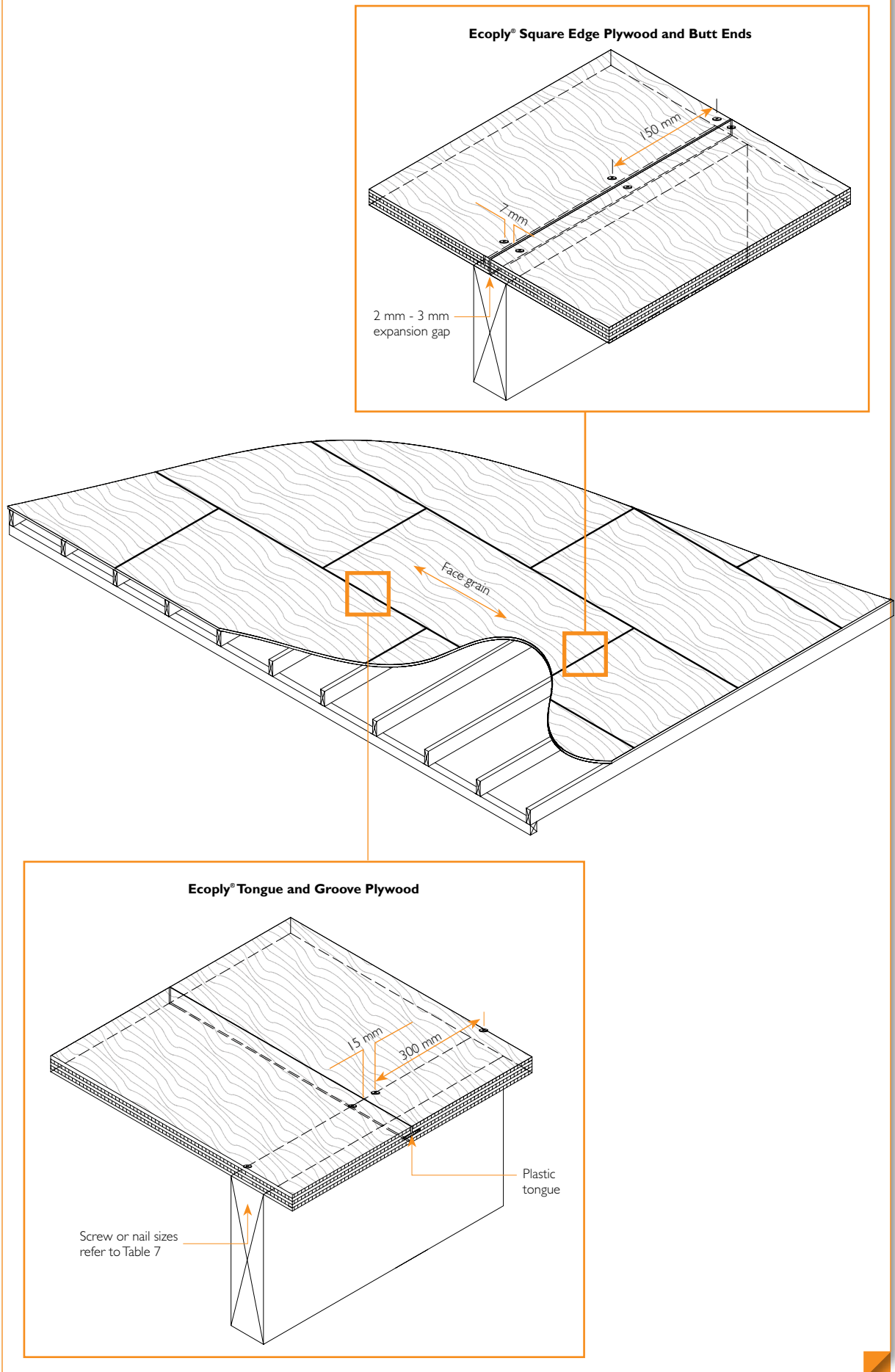

TABLE 7: FASTENERS AND CHARACTERISTIC SHEAR LOADS FOR ECOPLY®

Nominal Thickness (mm)	7 & 9 mm	Load ¹	12 & 15 mm	Load ¹	17 mm	Load ¹	19 to 21 mm	Load ¹	25 mm	Load ¹
Minimum nail size in timber studs	40 x 2.5 mm	570	60 x 2.8 mm	710	60 x 2.8 mm	710	60 x 2.8 mm	710	75 x 3.15 mm	883
Screw size in timber studs	No.8 x 30 mm	1230	No.8 x 40 mm	1230	No.10 x 40 mm	1650	No.10 x 45 mm	1650	No.10 x 50 mm	1650
Screw size in 1.15 mm steel studs²	10-24-35 ³	1300	10-24-40 ³	2000	10-16-45 ³	2100	10-16-45 ³	2100	10-16-45 ³	2100
Screw size in 2.80 mm steel studs²	10-24-35 ³	1200	10-16-40 ³	1200	14-20-45 ³	3000	14-20-45 ³	4000	14-20-45 ³	5000

¹ The load is the characteristic load (N) for one fastener in single shear

² Self tapping, self countersinking screw

³ Screw Numbers indicate: Gauge – Threads per inch – Length (mm)

- Steel thickness, screw sizes, characteristic loads, refer to assemblies actually tested
- Other screw sizes may be used. Screw properties vary between screw suppliers and the suitability of a particular size should be verified by the designer for performance under changing physical conditions and cyclic loading
- Non-standard nailing may be specifically designed with NZS 3603 or similar

Fasteners for H3.2 CCA treated Ecoply®

Where fasteners are in contact with H3.2 CCA treated timber or plywood, fasteners shall be a minimum of hot dip galvanised. In certain circumstances stainless steel fasteners may

be required. Refer to section 4 of NZS 3604 for these circumstances. Where stainless steel nails are required, annular grooved nails must be used.

2.3 ADHESIVES

Tube applied construction adhesives

Site applied construction adhesives may be used together with nails and screws for non permanent loads, reduced fastener popping, and to lower the risk of squeaking in floors. Available types include polyurethane (e.g. Holdfast® Gorilla Nailpower®) and elastomeric (e.g. Bostik® Wallboard Gold) based adhesives.

Elastomeric adhesives should meet the requirements of APA Performance specification AFG 01 *Adhesives for field gluing plywood to wood framing*. Other types should have appraisal from an independent authorising body such as BRANZ or equivalent authorities for the specific applications proposed. Follow manufacturers' recommendations. In addition:

- Use a bead or daubs of adhesive as per manufacturers' recommendations
- Apply pressure using fastener patterns outlined in section 2.2: Sheet fasteners and fixing
- Work from the middle of the sheet outwards to develop glue-line pressure
- Ensure adhesives are compatible with treatment in the framing timber; see section 1.4: Preservative treatment

Structural adhesive joints

Structural bonds are generally only achievable in factory controlled conditions using approved structural adhesives in accordance with approved standards for glue lamination, e.g. Resorcinol formaldehyde joints made to AS/NZS 1328 *Glued laminated structural timber*. Site gluing is not recommended for structural plywood components. Contact the Ecoply® help line on 0800 326 759 for further information.

3.0 STRUCTURAL BRACING & CEILING DIAPHRAGMS

The Ecoply® bracing system provides bracing resistance for walls and subfloor foundations for light timber framed buildings under wind and earthquake loading, to meet the requirements of the NZ Building Code - B1 Structure, and NZS 3604 *Timber Framed Buildings* or specifically designed to NZS 3603 *Timber Structures Standard*.

Any Ecoply structural panel may be used for bracing as long as it is equal to or greater than 7 mm thickness, has a minimum wall length as described in Table 9, treated for the specific

application in accordance with NZS 3602 (summarised in Table 8) and fixed in accordance with Ecoply bracing specifications outlined in this publication.

Shadowclad® exterior cladding, direct-fixed to framing or installed over 20 mm cavity battens, may be used for bracing when installed in accordance with the Shadowclad Specification & Installation Guide.

3.1 DESIGN TO COMPLY WITH THE NEW ZEALAND BUILDING CODE

Structure

Timber framed buildings to NZS 3604

NZS 3604 *Timber Framed Buildings* is listed as an Acceptable Solution under clause 3.0 Timber in Acceptable Solution B1/AS1 Structure.

CHH Woodproducts have developed a range of wall bracing elements tested using P21 testing methods referenced in NZS 3604:2011.

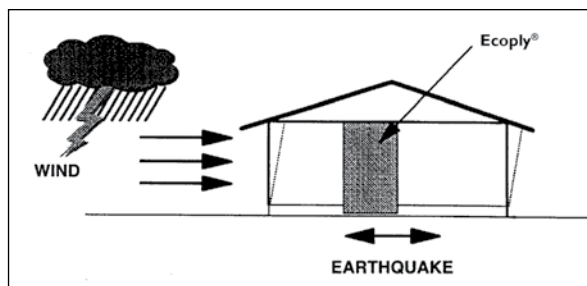

Specific design

Because Ecoply is structural plywood manufactured to AS/NZS 2269, it is suitable for design and use in earthquake and wind bracing systems constructed in accordance with NZS 3603 and AS/NZS 1170.

Structural plywood to AS/NZS 2269 is the only sheet brace material with properties defined in a published New Zealand engineering design code, NZS 3603 *Timber Structures*, and so can be designed in compliance with Verification method B1/VM1 under clause 6.0 Timber for use in buildings over three storeys in height.

Demand is calculated by following Section 5, Bracing Design of NZS 3604 or using the GIB Ezy-Brace software, downloadable from www.gib.co.nz

EP bracing systems properties can be easily loaded into the Ezy-Brace software by way of an Excel patch downloadable from www.chhwoodproducts.co.nz/ecoply-bracing together with loading instructions.

Because of changes made in the way the P21 racking test is analysed, BU's have been slightly downgraded in some instances from previous publications.

As a consequence of these changes, historical bracing systems (commonly referred to as the SP bracing series) will not meet the requirements of NZS 3604 and will not be an acceptable system from the 1st of January 2012.

Timber Floors

When carrying out a bracing design for buildings with timber floor structures, the maximum bracing rating that can be accounted for when summing up the bracing units is 120 BUs/m. This does not exclude the installation of bracing elements that are rated higher than 120 BUs/m, however the extra bracing capacity can not be accounted for in the bracing design.

Specific design of floor and sub-floor framing is required for elements rated higher than 120 BUs/m.

Durability

Ecoply plywood is manufactured to meet the requirements of NZS 3602 Timber and Wood based products for use in Buildings. If the product is used, handled and installed in accordance with CHH Woodproducts product literature it will meet the durability clauses of the NZ Building Code.

Table 8 summarises the applications in which Ecoply can be used as structural bracing together with the preservative treatment and fastener material required.

TABLE 8: ECOPLY® SUITABILITY FOR BRACING APPLICATIONS INCLUDING TREATMENT TYPE AND FASTENER MATERIAL

Application	Plywood Treatment	Fastener Material
Plywood bracing in interior spaces with no risk of exposure to weather or moisture penetration conducive to decay (all exposure zones¹ including sea spray): E.g. Interior linings	Ecoply Untreated	Hot dipped galvanised or better
Plywood bracing in enclosed spaces (protected from the weather) but with a risk of moisture penetration conducive to decay in exposure zones¹ B & C: E.g. Plywood bracing and/or rigid underlay (rigid air barrier), fixed to framing with/ without building paper/ wrap over, with/ without cavity battens behind cladding	Ecoply H3 treated Ecoply Barrier (rigid air barrier)	Hot dipped galvanised or better
Plywood bracing in enclosed spaces (protected from the weather) but with a risk of moisture penetration conducive to decay in exposure zone¹ D (sea spray): E.g. Plywood bracing and/or rigid underlay (rigid air barrier), fixed to framing with/without building paper/wrap over, with/without cavity battens behind cladding	Ecoply H3 treated Ecoply Barrier (rigid air barrier)	Stainless steel
Plywood bracing exposed to exterior weather conditions and dampness but not in contact with ground in exposure zones¹ B & C: E.g. Plywood used as both cladding and bracing (direct fixed to framing or over a drained ventilated cavity system)	Refer to Shadowclad® Specification and Installation Guide	
Plywood bracing exposed to exterior weather conditions and dampness but not in contact with ground in exposure zones¹ D (sea spray): E.g. Plywood used as both cladding and bracing (direct fixed to framing or over a 20 mm drained ventilated cavity system)	Refer to Shadowclad Specification and Installation Guide	
Bracing on framing exposed to ground atmosphere in exposure zones¹ B & C	Ecoply H3 treated	Hot dipped galvanised or better
Bracing on framing exposed to ground atmosphere in exposure zones¹ D	Ecoply H3 treated	Stainless steel
Bracing in wet process buildings in all exposure zones¹ (including sea spray)	Ecoply H3 treated	Stainless steel

¹ Exposure zones as per section 4 of NZS 3604

Rain wetting and construction bracing

Untreated Ecoply® will withstand normal exposure conditions during construction for up to 3 months however aesthetically the sheet appearance will deteriorate as the level of exposure increases. Rain and exposure can cause thinner plywood panels to buckle. Plywood stability is related to the number of veneers and thickness of the panel. Where panel stability is critical, consider using thicker panels.

Humidity and condensation

In uses where the moisture content may exceed 18% for prolonged periods, Ecoply must be H3 treated to resist decay or insect hazard.

Subfloor sheet bracing

H3 treated Ecoply can be used as sheet bracing where dampness does not allow the use of untreated plywood or other sheet materials (section 5 of NZS 3604). Where Ecoply subfloor sheet bracing is exposed to both rain and sun, it must be coated with a three coat, maintained acrylic exterior coating system with a light reflectance value of 40% or greater.

Adjustments for wall height

Use section 5 of NZS 3604 to calculate bracing values:

“Adjustment of bracing capacity of walls of different heights and walls with sloping top plates shall be obtained by the following method:

- For wall bracing elements of heights other than 2.4 m, the bracing rating determined by test or from Table 9 should be multiplied by $2.4 \div$ element height in metres, except that elements less than 2.4 m high shall be rated as if they are 2.4 m high.
- Walls of varying heights, should have their bracing capacity adjusted in accordance with section 5 of NZS 3604 using the average height.”

Joining panels for walls higher than maximum sheet length

Ecoply bracing panels must be fixed from top plate to bottom plate (with the exception of bracing specification of EPGs). For wall heights over 2.4 m, Ecoply and Shadowclad is available in 2.7 m sheet lengths. Alternatively, a part sheet can be stacked above a full sheet, butt joined on a single row of nogs with each sheet/part sheet independently nailed off as per the nail spacing in the Ecoply bracing specifications (e.g. 2.4 m x 1.2 m sheet with a 0.3 m x 1.2 m part sheet above it to give a 2.7 m x 1.2 m bracing element).

Cladding as bracing

Shadowclad® is recommended as a cladding which can be used for bracing as well.

12 mm EcoPLY® (CD face grade or better) can be H3 treated to meet the requirements of Acceptable Solution E2/AS1 and will perform as a structural, durable and weather tight cladding and bracing element when installed in accordance with the specifications in the Shadowclad Specification and Installation Guide.

However smooth faced plywood such as EcoPLY may be prone to appearance related issues such as face checking which occurs naturally and is not considered by CHH Woodproducts to be a manufacturing or product fault. For more information refer to section 1.8: Face checks on plywood exposed to weather: H3.2 CCA treated EcoPLY may also have a green tinge to the wood surface and may have fillet marks on the face of the sheet.

For exterior cladding applications where a high visual appearance is desired, CHH Woodproducts strongly recommends the use of Shadowclad as an exterior cladding. Shadowclad has a bandsawn face which helps reduce the incidence and appearance of face checking and is most commonly H3.1 LOSP treated (clear preservative treatment) which does not leave fillet marks on the panel face.

For further information on Shadowclad and plywood as an exterior cladding refer to the Shadowclad Specification and Installation Guide.

Soil

EcoPLY must not be allowed to come in contact with soil. The bottom edge of the plywood sheet must be a minimum of 100 mm above decks or paved ground and a minimum of 175 mm above unprotected ground.

Service penetrations in bracing elements

Small openings (e.g. power outlets) of 90 x 90 mm or less may be placed no closer than 90 mm to the edge of the braced element, or waste pipe outlets of max. 150 mm diameter placed at no closer than 150 mm to the edge of the braced element.

3.2 ECOPLY® BRACING SPECIFICATIONS SUMMARY

CHH Woodproducts has a range of bracing specifications called the EP bracing series. The EP bracing series simplifies the design and construction of bracing elements using plywood, by itself or in conjunction with GIB® Plasterboard.

- Reduced number of element types and simplified naming system
- Single sided and double sided bracing elements
- Special EPGs bracing element design for where plywood cladding comes to soffit line within 300 mm of top plate
- High performance bracing element utilising GIB® Standard plasterboard
- A single type, GIB Handibrac®, hold-down for all bracing elements
- Direct fix or cavity construction
- Simplified construction
- Specifications for each bracing element type

Historical Ecoply® bracing specifications (commonly referred to as the SP bracing series) can still be used in bracing design until the 31st of December 2011. At this time the SP bracing series will be officially withdrawn from CHH Woodproducts bracing specifications to meet the recent changes in NZS 3604:2011.

Where the cladding forms part of the structural bracing refer to Shadowclad Specification and Installation Guide for specifications.

Up until the 31st of December 2011 SP bracing series specifications can be downloaded from www.chhwoodproducts.co.nz/ecoply-bracing

TABLE 9: SUMMARY P21 RATINGS FOR 2.4 M HIGH ECOPLY® WALL ELEMENTS

Specification No.	Minimum Wall Length	Lining Requirements	BU's/m Wind	BU's/m Earthquake
EP1	0.6 m	7 mm Ecoply or Ecoply Barrier one side	125	130
EP2	0.6 m	7 mm Ecoply or Ecoply Barrier each side	140	150
EPG	0.4 m	7 mm Ecoply or Ecoply Barrier one side and	100	115
	1.2 m	10 mm GIB® Standard plasterboard other side	150	150
EPGs	0.4 m	7 mm Ecoply or Ecoply Barrier one side*	100	115
	1.2 m	and 10 mm GIB® Standard plasterboard other side	150	120

* Plywood side of element must be a maximum of 300 mm below top plate

Note: Bracing and other technical information has been specifically tested using Ecoply and Shadowclad branded structural plywood. This information cannot be used with any other plywood brand and bracing data must be sought directly from the specific plywood manufacturer.

More information

The following pages provide a full specification of EP bracing elements. Copies of specifications can be downloaded from www.chhwoodproducts.co.nz/ecoply-bracing

NZS 3604 provides the method of calculating demand on a building. Calculation sheets are available from BRANZ or GIB® EzyBrace™ software is available as a free download from www.gib.co.nz. Information is available at www.chhwoodproducts.co.nz which can be placed in the custom elements of GIB® EzyBrace™ for ease of calculation.

Ecoply® Bracing Systems are designed to meet the requirements of the New Zealand Building Code and have been tested and analysed using the P21 method referenced in NZS 3604:2011 listed as an acceptable solution B1/AS1 Structure. Testing was carried out using Ecoply and Laserframe SG8 timber framing manufactured by

Carter Holt Harvey Limited trading as CHH Woodproducts New Zealand, and GIB® products manufactured by Winstone Wallboards Ltd. Substituting materials may compromise performance of the system. GIB® and GIB HandiBrac® are registered trade marks of Fletcher Building Holdings Ltd.

3.3 ECOPLY® BRACING SPECIFICATION – EPI

SINGLE SIDED STRUCTURAL PLYWOOD BRACE

Specification No.	Minimum Wall Length	Lining Requirements	BU's/m Wind	BU's/m Earthquake
EPI	0.6 m	7 mm Ecoply® or Ecoply Barrier one side	125	130

Framing

Wall framing must comply with:

- NZBC B1 - Structure: AS1 Clause 3 Timber (NZS 3604:2011)
- NZBC B2 - Durability: AS1 Clause 3.2 Timber (NZS 3602)

Framing dimensions and height are as determined by the NZS 3604 stud and top plate tables for load bearing and non load bearing walls. Kiln dried verified structural grade timber must be used. Machine stress graded timber, such as Laserframe®, is recommended.

Bottom plate fixing

Use GIB Handibrac® hold-down connections at each end of the bracing element. Refer to manufacturer installation instructions supplied with the connectors for correct installation instructions and bolt types to be used for either concrete or timber floors. Within the length of the bracing element, bottom plates are fixed in accordance with the requirements of NZS 3604.

Lining

One layer of 7 mm Ecoply plywood or Ecoply® Barrier fixed directly to framing or over cavity battens. If part sheets are used, ensure nailing at required centres is carried out around the perimeter of each sheet or part sheet. A 2-3 mm expansion gap should be left between sheets.

Fastening the Ecoply®

Fasteners

Fasten with 50 x 2.8 mm galvanised or stainless steel flat head nails for direct fix, or 60 x 2.8 mm over cavity battens. Place fasteners no less than 7 mm from sheet edges.

Fasteners for H3.2 CCA treated Ecoply

Where fasteners are in contact with H3.2 CCA treated timber or plywood, fasteners shall be a minimum of hot dip galvanised.

In certain circumstances stainless steel fasteners may be required. Refer to table 8 of the Ecoply Specification and Installation Guide for these circumstances and further fastener selection advice.

Where stainless steel nails are required, annular grooved nails must be used.

Fastening centres

Fasteners are placed at 150 mm centres around the perimeter of each sheet and 300 mm centres to intermediate studs. Where more than one sheet forms the brace element each sheet must be nailed off independently.

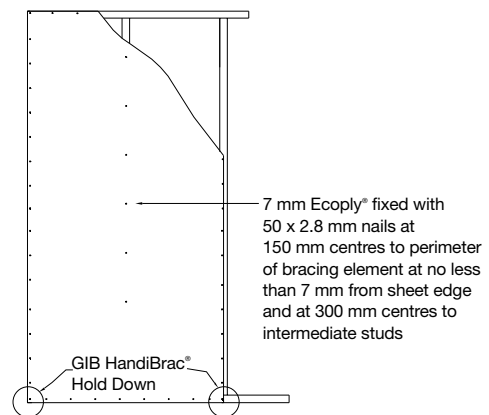

Ecoply® Bracing Systems are designed to meet the requirements of the New Zealand Building Code and have been tested and analysed using the P21 method referenced in NZS 3604:2011 listed as an acceptable solution B1/AS1 Structure. Testing was carried out using Ecoply and Laserframe SG8 timber framing manufactured by

Carter Holt Harvey Limited trading as CHH Woodproducts New Zealand, and GIB® products manufactured by Winstone Wallboards Ltd. Substituting materials may compromise performance of the system. GIB® and GIB Handibrac® are registered trade marks of Fletcher Building Holdings Ltd.

3.4 ECOPLY® BRACING SPECIFICATION – EP2

DOUBLE SIDED STRUCTURAL PLYWOOD BRACE

Specification No.	Minimum Wall Length	Lining Requirements	BUs/m Wind	BUs/m Earthquake
EP2	0.6 m	7 mm Ecoply® or Ecoply Barrier each side	140	150

Framing

Wall framing must comply with:

- NZBC B1 - Structure:AS1 Clause 3 Timber (NZS 3604:2011)
- NZBC B2 - Durability:AS1 Clause 3.2 Timber (NZS 3602)

Framing dimensions and height are as determined by the NZS 3604 stud and top plate tables for load bearing and non load bearing walls. Kiln dried verified structural grade timber must be used. Machine stress graded timber, such as Laserframe®, is recommended.

Bottom plate fixing

Use GIB Handibrac® hold-down connections at each end of the bracing element. Refer to manufacturer installation instructions supplied with the connectors for correct installation instructions and bolt types to be used for either concrete or timber floors. Within the length of the bracing element, bottom plates are fixed in accordance with the requirements of NZS 3604.

Lining

Each Side: One layer of 7 mm Ecoply plywood or Ecoply® Barrier fixed directly to framing or over cavity battens. If part sheets are used, ensure nailing at required centres is carried out around the perimeter of each sheet or part sheet. A 2-3 mm expansion gap should be left between sheets.

Fastening the Ecoply®

Fasteners

Fasten with 50 x 2.8 mm galvanised or stainless steel flat head nails for direct fix, or 60 x 2.8 mm over cavity battens. Place fasteners no less than 7 mm from sheet edges.

Fasteners for H3.2 CCA treated Ecoply

Where fasteners are in contact with H3.2 CCA treated timber or plywood, fasteners shall be a minimum of hot dip galvanised.

In certain circumstances stainless steel fasteners may be required. Refer to table 8 of the Ecoply Specification and Installation Guide for these circumstances and further fastener selection advice.

Where stainless steel nails are required, annular grooved nails must be used.

Fastening centres

Fasteners are placed at 150 mm centres around the perimeter of each sheet and 300 mm centres to intermediate studs. Where more than one sheet forms the brace element each sheet must be nailed off independently.

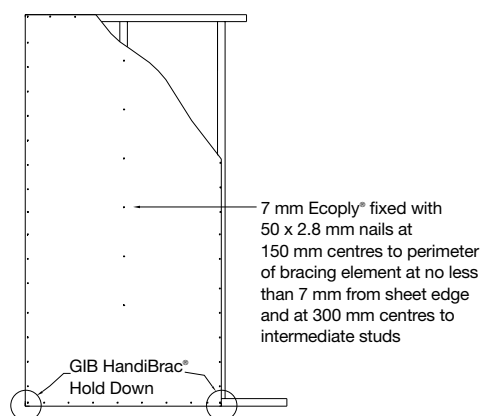

Ecoply® Bracing Systems are designed to meet the requirements of the New Zealand Building Code and have been tested and analysed using the P21 method referenced in NZS 3604:2011 listed as an acceptable solution B1/AS1 Structure. Testing was carried out using Ecoply and Laserframe SG8 timber framing manufactured by

Carter Holt Harvey Limited trading as CHH Woodproducts New Zealand, and GIB® products manufactured by Winstone Wallboards Ltd. Substituting materials may compromise performance of the system. GIB® and GIB Handibrac® are registered trade marks of Fletcher Building Holdings Ltd.

3.5 ECOPLY® BRACING SPECIFICATION – EPG

STRUCTURAL PLYWOOD BRACE WITH PLASTERBOARD OTHER SIDE

Specification No.	Minimum Wall Length	Lining Requirements	BU's/m Wind	BU's/m Earthquake
EPG	0.4 m	7 mm Ecoply® or Ecoply Barrier one side and 10 mm GIB® Standard plasterboard other side	100	115
	1.2 m		150	150

Framing

Wall framing must comply with:

- NZBC B1 - Structure: AS1 Clause 3 Timber (NZS 3604:2011)
- NZBC B2 - Durability: AS1 Clause 3.2 Timber (NZS 3602)

Framing dimensions and height are as determined by the NZS 3604 stud and top plate tables for load bearing and non load bearing walls. Kiln dried verified structural grade timber must be used. Machine stress graded timber, such as Laserframe®, is recommended.

Bottom plate fixing

Use GIB HandiBrac® hold-down connections at each end of the bracing element. Refer to manufacturer installation instructions supplied with the connectors for correct installation instructions and bolt types to be used for either concrete or timber floors. Within the length of the bracing element, bottom plates are fixed in accordance with the requirements of NZS 3604.

Lining

Side 1: One layer of 7 mm Ecoply plywood or Ecoply® Barrier exterior wall cladding fixed directly to framing or over cavity battens. If part sheets are used, ensure nailing at required centres is carried out around the perimeter of each sheet or part sheet. A 2-3 mm expansion gap should be left between sheets.

Side 2: One layer of 10 or 13 mm GIB® Standard plasterboard vertically or horizontally fixed. Sheet joints are touch fitted and fastener heads and joints stopped in accordance with the GIB® Site Guide.

Fastening the Ecoply®

Fasteners

Fasten with 50 x 2.8 mm galvanised or stainless steel flat head nails for direct fix, or 60 x 2.8 mm over cavity battens. Place fasteners no less than 7 mm from sheet edges.

Fasteners for H3.2 CCA treated Ecoply

Where fasteners are in contact with H3.2 CCA treated timber or plywood, fasteners shall be a minimum of hot dip galvanised.

In certain circumstances stainless steel fasteners may be required. Refer to table 8 of the Ecoply Specification and Installation Guide for these circumstances and further fastener selection advice.

Where stainless steel nails are required, annular grooved nails must be used.

Fastening centres

Fasteners are placed at 150 mm centres around the perimeter of each sheet and 300 mm centres to intermediate studs. Where more than one sheet forms the brace element each sheet must be nailed off independently.

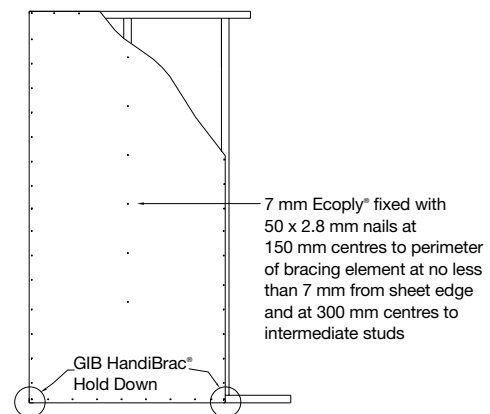

Ecoply® Bracing Systems are designed to meet the requirements of the New Zealand Building Code and have been tested and analysed using the P21 method referenced in NZS 3604:2011 listed as an acceptable solution B1/AS1 Structure. Testing was carried out using Ecoply and Laserframe SG8 timber framing manufactured by

Carter Holt Harvey Limited trading as CHH Woodproducts New Zealand, and GIB® products manufactured by Winstone Wallboards Ltd. Substituting materials may compromise performance of the system. GIB® and GIB HandiBrac® are registered trade marks of Fletcher Building Holdings Ltd.

Fastening the GIB® Plasterboard

Fasteners

32 mm x 6 g GIB® Grabber® Screws or 35 mm GIB® Nails

Fastening centres

Fasten 50, 100, 150, 225 and 300 mm from each corner and 150 mm thereafter around the perimeter of the bracing element. For vertical fixing place fasteners at 300 mm centres at intermediate sheet joints. For horizontal fixing place single fasteners in the tapered edge where sheets cross studs.

Place fasteners 12 mm from paper bound edges and 18 mm from cut sheet edges. GIB® plasterboard must be treated in every respect in accordance with relevant GIB® literature.

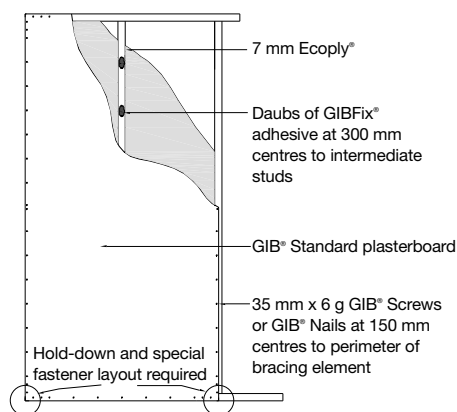

Ecoply® Bracing Systems are designed to meet the requirements of the New Zealand Building Code and have been tested and analysed using the P21 method referenced in NZS 3604:2011 listed as an acceptable solution B1/AS1 Structure. Testing was carried out using Ecoply and Laserframe SG8 timber framing manufactured by

Carter Holt Harvey Limited trading as CHH Woodproducts New Zealand, and GIB® products manufactured by Winstone Wallboards Ltd. Substituting materials may compromise performance of the system. GIB® and GIB HandiBrac® are registered trade marks of Fletcher Building Holdings Ltd.

3.6 ECOPLY® BRACING SPECIFICATION – EPGs

A BRACING ELEMENT SPECIALLY DESIGNED FOR SHEETS TO TERMINATE AT SOFFIT HEIGHT

Specification No.	Minimum Wall Length	Lining Requirements	BU's/m Wind	BU's/m Earthquake
EPGs	0.4 m	7 mm Ecoply® or Ecoply Barrier one side and 10 mm GIB® Standard plasterboard other side	100	115
	1.2 m		150	120

Framing

Wall framing must comply with:

- NZBC B1 - Structure: AS1 Clause 3 Timber (NZS 3604:2011)
- NZBC B2 - Durability: AS1 Clause 3.2 Timber (NZS 3602)

Framing dimensions and height are as determined by the NZS 3604 stud and top plate tables for load bearing and non load bearing walls. Kiln dried verified structural grade timber must be used. Machine stress graded timber, such as Laserframe®, is recommended.

Bottom plate fixing

Use GIB HandiBrac® hold-down connections at each end of the bracing element. Refer to manufacturer installation instructions supplied with the connectors for correct installation instructions and bolt types to be used for either concrete or timber floors. Within the length of the bracing element, bottom plates are fixed in accordance with the requirements of NZS 3604.

Lining

Side 1: One layer of 7 mm Ecoply plywood or Ecoply® Barrier fixed directly to framing or over cavity battens. If part sheets are used, ensure nailing at required centres is carried out around the perimeter of each sheet or part sheet. A 2-3 mm expansion gap should be left between sheets. The Ecoply may terminate within a maximum of 300 mm below the top of the top plate, e.g. at soffit line, where solid nogging must be provided for the full length of the bracing element to provide for fixing of the Ecoply.

Side 2: One layer of 10 or 13 mm GIB® Standard plasterboard vertically or horizontally fixed. Sheet joints are touch fitted and fastener heads and joints stopped in accordance with the GIB® Site Guide.

Fastening the Ecoply®

Fasteners

Fasten with 50 x 2.8 mm galvanised or stainless steel flat head nails for direct fix, or 60 x 2.8 mm over cavity battens. Place fasteners no less than 7 mm from sheet edges.

Fasteners for H3.2 CCA treated Ecoply

Where fasteners are in contact with H3.2 CCA treated timber or plywood, fasteners shall be a minimum of hot dip galvanised.

In certain circumstances stainless steel fasteners may be required. Refer to table 8 of the Ecoply Specification and Installation Guide for these circumstances and further fastener selection advice.

Where stainless steel nails are required, annular grooved nails must be used.

Fastening centres

Fasteners are placed at 150 mm centres around the perimeter of each sheet and 300 mm centres to intermediate studs. Where more than one sheet forms the brace element each sheet must be nailed off independently.

Fastening to cavity battens

The plywood side of the brace element may be fixed over cavity battens.

The cavity battens must be a minimum of 40 x 2.0 mm nailed in staggered formation at 150 mm centres to studs around the perimeter of the brace element, and nailed to the intermediate studs within the element at 300 mm centres. A minimum of 50 mm x 2.8 mm flat head galvanised or annular grooved stainless steel nails must be used.

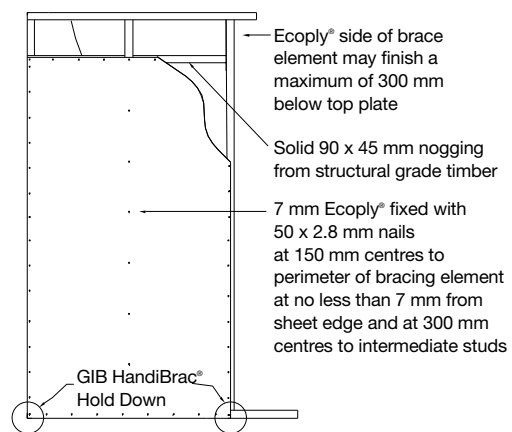

Ecoply® Bracing Systems are designed to meet the requirements of the New Zealand Building Code and have been tested and analysed using the P21 method referenced in NZS 3604:2011 listed as an acceptable solution B1/AS1 Structure. Testing was carried out using Ecoply and Laserframe SG8 timber framing manufactured by

Carter Holt Harvey Limited trading as CHH Woodproducts New Zealand, and GIB® products manufactured by Winstone Wallboards Ltd. Substituting materials may compromise performance of the system. GIB® and GIB HandiBrac® are registered trade marks of Fletcher Building Holdings Ltd.

Fastening the GIB® Plasterboard

Fasteners

32 mm x 6 g GIB® Grabber® Screws or 35 mm GIB® Nails

Fastening centres

Fasten 50, 100, 150, 225 and 300 mm from each corner and 150 mm thereafter around the perimeter of the bracing element. For vertical fixing place fasteners at 300 mm centres at intermediate sheet joints. For horizontal fixing place single fasteners in the tapered edge where sheets cross studs.

Place fasteners 12 mm from paper bound edges and 18 mm from cut sheet edges. GIB® plasterboard must be treated in every respect in accordance with relevant GIB® literature.

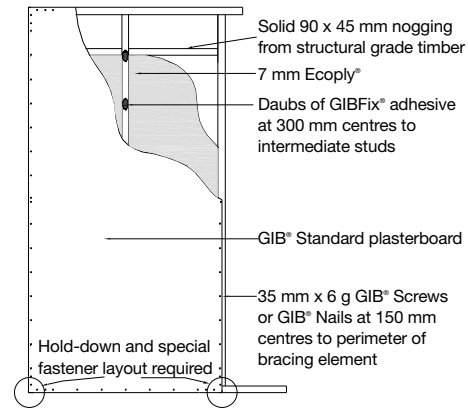

Ecoply® Bracing Systems are designed to meet the requirements of the New Zealand Building Code and have been tested and analysed using the P21 method referenced in NZS 3604:2011 listed as an acceptable solution B1/AS1 Structure. Testing was carried out using Ecoply and Laserframe SG8 timber framing manufactured by

Carter Holt Harvey Limited trading as CHH Woodproducts New Zealand, and GIB® products manufactured by Winstone Wallboards Ltd. Substituting materials may compromise performance of the system. GIB® and GIB HandiBrac® are registered trade marks of Fletcher Building Holdings Ltd.

3.7 GIB HANDIBRAC® - RECOMMENDED INSTALLATION METHOD

Developed in conjunction with MiTek™ NZ, the GIB HandiBrac® has been tested for use as a hold-down in all EP bracing elements.

- The GIB HandiBrac® registered design provides for quick and easy installation
- The GIB HandiBrac® provides a flush surface for the wall linings

because it is fitted inside the framing. There is no need to check in the framing as recommended with conventional straps

- The GIB HandiBrac® is suitable for both new and retrofit construction
- The design also allows for installation and inspection at any stage prior to fitting internal linings

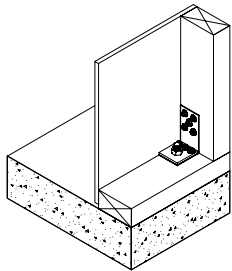
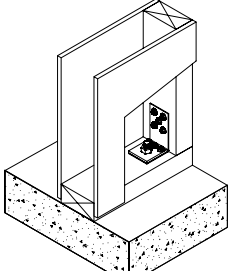
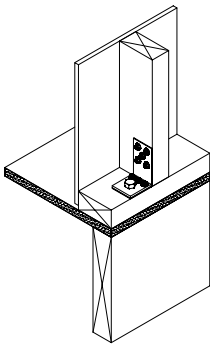
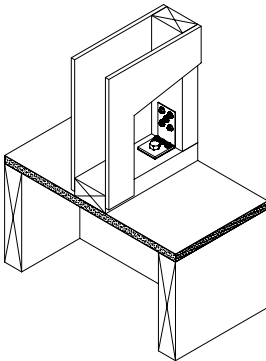
Concrete Floor		Timber Floor	
External walls	Internal walls	External walls	Internal walls
			
Position GIB HandiBrac® as close as practicable to the internal edge of the bottom plate	Position GIB HandiBrac® at the stud/plate junction	Position GIB HandiBrac® in the centre of the perimeter joist or bearer	Position GIB HandiBrac® in the centre of the floor joist or full depth solid block
Hold-down fastener requirements			
A mechanical fastening with a minimum characteristic uplift capacity of 15kN or screw bolt supplied with the bracket		12 x 150 mm galvanised coach screw or screw bolt supplied with the bracket	

Reproduced with the permission of Winstone Wallboards Ltd

3.8 STRUCTURAL CEILING DIAPHRAGMS

Diaphragms are used to transfer lateral loads to braced walls and allow for greater spacing between bracing lines. Diaphragms do not have a BU rating themselves.

Plywood diaphragms are an acceptable solution as described in section 13 NZS 3604 13.5.2 and allows for plywood not less than 6 mm thick and a minimum of three ply for:

- Diaphragms not steeper than 25 degrees to the horizontal and not exceeding 10 metres long under light or heavy roofs and;
- Diaphragms not steeper than 45 degrees to the horizontal and not exceeding 7.5 metres long under light or heavy roofs

Ceiling Diaphragms are constructed as follows:

- The length of diaphragm shall not exceed twice its width measured between supporting walls
- The ceiling lining must consist of plywood over the entire area of the diaphragm
- Complete sheets with a minimum size of 1800 x 900 must be used
- Framing size and spacing must comply with NZS 3604
- Fastener size should comply with Table 7 of this publication. E.g. 40 mm x 2.5 mm flat head nails for 7 mm and 9 mm EcoPLY
- Fastening is at 150 mm centres around the perimeter of each sheet and at 300 mm centres to intermediate framing
- Fixings are no closer than 10 mm from sheet edges
- Perimeter ceiling framing must be connected to wall framing by a perimeter 140 mm x 35 mm ribbon plate nailed to the top of the top plate or alternative such as a 0.55 mm thick steel angle or proprietary steel channel

4.0 INTERNAL LININGS, SOFFITS AND APPEARANCE PLYWOOD

The below section relates to the use of Ecoply® appearance plywoods in internal and soffit lining applications.

Appearance plywood (Ecoply Structural Square Edge BB and BD face grades and Ecoply Grooved Lining - often referred to as "Plygroove") are specifically referenced in this section however where a high visual face grade is not required the use of lower visual grades such as Ecoply CD and DD grades may be used.

For more information on Ecoply surface grades see section 1.3: Surface grades.

Advantages

- Decorative real wood panelling
- Tough and impact resistant
- Strong, providing stiffness and rigidity
- No special tools required
- Easy to work and finish
- Ability to create slight curves
- Cost effective
- Water-resistant glue bond

Applications

- Interior wall and ceiling linings
- Feature walls and partitions
- Back lining to exposed rafters
- Commercial interiors and shop fitouts
- Soffit lining (where H3.1 LOSP treated)
- Furniture and cabinets

4.1 PRODUCT RANGE

TABLE 10: ECOPLY® APPEARANCE PRODUCT RANGE

Thickness (mm)	No. of plies	Sheet Length x 1200 mm	Structural Square Edge		Grooved Lining
			BB	BD	Classic & Prime
9	3	2400		•	
12	5	2400	•	•	•
12	5	2700		•	•
15	5	2400		•	
17	7	2400	•	•	

All appearance plywoods are available either untreated or H3.1 LOSP treated (9 mm BD - available untreated only). Other sizes and thicknesses may be available on request. Contact CHH Woodproducts on 0800 326 759.

Structural square edge products

- BB grade features a solid sanded 'B' grade appearance on both sides. Suitable for applications where both sides of the panel will be visible and appearance is important
- BD grade features a solid sanded 'B' grade appearance face with an unsanded 'D' back. Suitable for applications where one side of the panel will be visible and appearance is important

Grooved lining products

Grooved Lining is a 12 mm thick sheet with a solid sanded 'B' grade appearance face with an unsanded 'D' back. It features 4 mm wide by 2 mm wide deep 'V' grooves running the length of the sheet at 100 mm centres and is available untreated for internal dry applications or H3.1 LOSP treated for internal damp or semi exposed exterior applications (such as soffit linings).

Grooved Lining is not recommended for use as an exposed exterior cladding due to the potential of appearance issues such as face checking. For more information on face checking see section 1.8: Face checks on plywood exposed to weather.

Grooved Lining is available in two finishes.

Classic Grade: Featuring a B face with natural features for a refined wood appearance suitable for clear and stain finishes.

Prime Grade: Features a pre primed surface allowing time and labour savings when painting.

When using Grooved Lining Prime some coating manufacturers may require an additional wet primer coating for speciality top coat systems. Always refer to the coating manufacturer's specifications prior to coating.

Note: All sheets containing a single visual side (such as Ecoply BD) have product identification markings on the sheet rear: All sheets with visual faces on both sides of the panel (such as Ecoply BB) are unmarked.

4.2 INTERNAL LININGS AND SOFFITS - DESIGN CONSIDERATIONS

Internal wall linings

- Use 2700 mm sheets where available for high stud walls
- Skirtings, dado mouldings, furniture trim, bookshelves, cornices and other trim can be used to hide mechanical fasteners
- Deep skirting and cornices can be used to extend the effective length of shorter sheets in longer applications
- Unsupported plywood sheets may twist with environmental changes or when coated, particularly if the coating is applied to one side only. Where on going sheet flatness is critical, plywood sheets must be supported by framing
- EcoPLY® appearance plywood may be used for structural bracing. Refer to section 3.0: Structural bracing and ceiling diaphragms

Internal ceilings and soffits

- For internal ceilings and soffits (semi exposed to weather) which are visible from underneath use EcoPLY Grooved Lining, B face grade Structural Square Edge or Shadowclad® installed with the face down
- For internal/moisture free applications use untreated plywood

Exterior soffits

- Use a minimum 12 mm thickness
- Use H3.1 LOSP treated product. Do not use water based preservative treatments

- Allow a 2-3 mm expansion gap between square edge sheets
- Use a good quality paint or stain to protect the plywood from intermittent wetting and wind blown moisture

Appearance plywood in exposed exterior applications

- Appearance plywood is primarily designed for internal applications (untreated) but H3 treated product can be used for sheltered exterior applications such as soffit linings
- Appearance plywood is not recommended for use in exposed exterior applications such as cladding. For cladding CHH Woodproducts recommends the use of Shadowclad exterior cladding
- If used in exposed exterior applications appearance products will meet the durability requirements of the NZ Building Code, however naturally occurring appearance issues (such as face checking and mould growth) may occur and are not considered a manufacturing fault by CHH Woodproducts. For more information refer to section 1.8: Face checks on plywood exposed to weather

Forming curves

- EcoPLY can be curved for applications such as ceilings and feature walls. Table 11 provides guidance for the minimum recommended radii

TABLE 11: BENDING RADII FOR ECOPLY® PRODUCTS

Recommended minimum bending radii for EcoPLY products				
Nominal thickness (mm)	9	12	15	17
Along face (m)	2.3	3.6	4.6	6.0
Across face (m)	1.3	2.4	3.0	4.4

4.3 INTERNAL LININGS AND SOFFITS - INSTALLATION

Pre Installation Inspection

- Prior to installation, inspect panels for visual defects. Responsibility lies with the installer to ensure individual panels meet the aesthetic requirements of the project. CHH Woodproducts will not be responsible for installation or removal costs where aesthetically unacceptable panels have been installed
- For best results install panels in as close to the final environmental conditions as possible
- Store panels in a dry, cool area

Sheet layout

- Maximum framing centres are shown in Table 12
- For all square edge sheets products must be supported at sheet edges
- For all sheet product with a tongue and groove edge, unless specified, tongue and groove edges do not need support - all other edges do
- Closer spacings are recommended in high impact areas e.g. bars, industrial or crowded spaces

TABLE 12: MAXIMUM FRAME SPACINGS FOR ECOPLY® PLYWOOD

Application		Maximum frame centre (mm)			
		EcoPLY® nominal thickness (mm)			
		9	12	15	17
Walls	1. Fixed vertically, max stud spacing without nogs or dwangs	400	600	600	600
	2. Fixed horizontally, maximum stud facing	600	600	1200	1200
Internal Ceilings or Soffits	3. Face grain across framing, under or over frame	-	900	1200	1200

- Avoid single spans between framing supports

4.4 FASTENERS & FIXING

Ecoply® appearance plywood can be installed using a variety of fastening and fixing methods depending on the degree of fastener concealment desired.

General fixing techniques include:

- Nailing (including panel pins), screw and gluing
- Use of scotia/ dado & skirtings to hide joints and fixings
- Battens and rafters to hide joints
- Creating design features of mechanical fasteners (such as use of rose head fasteners)
- Negative detailing between panel edges

Fixings for non bracing walls & ceilings

Nails: Use 40 mm panel pins at 150 mm centres at sheet edges and 300 mm centres on intermediate supports. Daubs of a polyurethane based adhesive such as Holdfast Gorilla Grip or Fix All 220 Sealant at 300 mm centres is recommended on all framing members.

Where back nailing over rafters use galvanised flat head nails 40 x 2.5 mm.

Screws: Use No.8 x 40 mm screws and adhesive as per nail specifications.

Adhesives Only (not suitable for ceiling applications)

Panels may be fixed with a bead of polyurethane based adhesive on all frame supports. Sheets must be supported by applying pressure during the adhesive curing process in accordance with the adhesive manufacturer specifications or with mechanical fasteners such as nails, panel pins or screws at 300 mm centres on all supporting framing.

Holdfast® Adhesive Only Wall System

Holdfast® has developed an installation method for Ecoply appearance plywood when used for internal wall linings (not suitable for use in ceiling applications).

The system uses a two stage process utilising Holdfast Fix All 220MS and Gator UHB double sided tape. The Gator tape provides initial fixing support for panels while a permanent bond is established using the Fix All 220MS.

When installed according to Holdfast technical specifications this system can eliminate the need for mechanical fasteners and/or bracing support during the adhesive curing process.

For specifications and technical support regarding this system contact Holdfast on 0800 70 10 80 or visit www.holdfast.co.nz to download specifications.

Forming curves - installation

- Shaped top and bottom plates or noggs can be jigsaw cut from 17, 19, 21 or 25 mm thick Ecoply
- Fix covering plywood over the framework
- Attach the out edges with tack nails or clamps first to develop the curve and then fix sheets from the centre out
- For load bearing curves check capability using a structural designer
- Use recommended fastener size as detailed in Table 7 at 150 mm centres on all frames. Longer fasteners, ring shank or annular grooved nails will provide improved resistance to tension. Adhesives are not normally recommended good in tension applications

4.5 INTERNAL LININGS AND SOFFITS - FINISHING

Punch nails before finishing and apply a first coat (clear; primer or sealer) before filling punched holes to minimise dryout or staining. High quality paints, stains or clear finishes are recommended for Ecoply appearance plywood. Tinted clear finishes can provide a full range of architectural options that show the warmth of wood while reducing yellowing and other ultraviolet effects. The use of high gloss finishes and paints tend to highlight naturally occurring and manufacturing characteristics of plywood such as changes in grain and beat marks from the

sanding. Matt finishes and paints are recommended to provide a natural timber finish.

Ecoply appearance plywoods are wood based and respond to changes in humidity. Avoid using inflexible coatings (such as epoxies) that may check on movement of the wood. For ceilings or similar applications it is an advantage to prefinish panels prior to installation. Always refer to the coating manufacturers' specifications for sustainability.

5.0 ROOFS AND DECKS

The section below covers the use of Ecoply® plywood used as a substrate for flexible membrane and tile systems in roofing and decking applications. They should be considered as supplementary to system specifications from roofing and decking suppliers.

Ecoply is not recommended as a substrate for exterior decks

without a properly detailed barrier material such as butyl rubber, vinyl or E.P.D.M to protect the surface from weathering.

Always refer to the roofing and decking system supplier for installation, plywood selection and surface preparation requirements for specific roofing and decking products.

5.1 FLEXIBLE MEMBRANE SYSTEMS

- Roofing and decking membranes may comprise synthetic rubber sheeting glued to the Ecoply, or torch welded bitumen membranes
- Always ensure Ecoply is dry and free of imperfections such as surface dust and blemishes as membranes coatings will telegraph any substrate imperfections
- Use Ecoply Flooring or Structural Square Edge (CD Grade)
- Where Ecoply Flooring is used consider the use of a small daub of glue in the Tongue & Groove of each sheet if potential movement of the plastic tongue joint is not acceptable
- For trafficable decks use a minimum 17 mm thickness
- Use countersunk stainless steel screws and adhesive on framing to avoid head popping. Apply adhesive between screw locations
- Use kiln dry framing or appropriate LVL framing from the Futurebuild™ range
- Tape over all joints to provide a bond break under the membrane to allow elongation with natural plywood movement
- Where treatment is required use only H3.2 CCA treated Ecoply. Do not use H3.1 LOSP treated Ecoply (solvent based carrier) which is not compatible with most membrane systems. If there is evidence of treatment salt crystals on the Ecoply surface remove by scrubbing with a small amount of water and allow the surface to dry prior to laying the membrane system
- Prepare surface with hot air or gas blow dryers to ensure wash, dew or rain water is driven off prior to laying membrane system

Plywood substrates, face checking and flexible membrane systems

All natural wood based products (including Ecoply) have the potential to develop natural surface face checks when exposed to external environmental conditions. The degree of potential face checking is dependent on a number of factors including the length of time and level of exposure to weather during construction which is outside the manufacturing control of CHH Woodproducts. For more information see section 1.8: Face checking in plywood exposed to weather.

Face checks while typically not present after manufacture, do not affect structural performance of the sheet and are acceptable under AS/ NZS 2269. They are not a manufacturing fault.

Designers and membrane suppliers must carefully consider the suitability of plywood as a substrate for the membrane system in question if the potential of telegraphing of face checks onto the membrane surface is not acceptable.

The risk of telegraphing can be reduced by protecting the plywood surface from weather and moisture during the construction process.

Where the potential of face checking in the plywood substrate is not acceptable designers should consult the membrane supplier for a more suitable membrane or an alternative substrate.

Allowing for moisture expansion of plywood under roof and floor coverings

Membrane suppliers have strongly held different views on the requirements for plywood substrates. The fixing instructions within this publication are the starting point but designers must detail joints that allow for expansion in accordance with practices recommended by the chosen membrane supplier.

CHH Woodproducts view, and the recommendation of a number of suppliers here and in North America, has been to allow for expansion and contraction at sheet edges by loosely butting tongue and grooved edges so that the tongues can absorb movement and providing a small gap (2 to 3 mm) between square sawn edges. Use a bond breaking tape over these joints to spread elongation in the membrane over a longer distance than the narrow gap in the joint itself. This tape can double as a rain seal over the sheet edges during construction.

Other membrane suppliers believe that sheets should be tightly butted and glued and screwed hard up to each other. This practice constrains movement at the small joint between sheets, but over a wider area requires significant allowance for movement around the perimeter of a roof segment. Junctions between the roof slopes and walls need careful detailing to allow for the potential movement. Movement control joints should be provided at regular intervals following the recommendation of the membrane manufacturer, especially if this method is adopted.

5.2 ROOF TILE SYSTEMS

Most fibreglass, asphalt or wooden shingle and tile systems will tolerate DD grade surface characteristics.

- Use unsanded Ecoply® Roofing (DD grade), or sanded Ecoply of the required thickness in Table 13A
- The unsanded surface provides extra grip on steeper roofs for roofing crews

- A plywood substrate can avoid the cost of battens
- Fix tiles according to tile manufacturer's specification
- Under asphalt shingles use saturated felt underlay over the Ecoply

5.3 ROOFING & DECKING - PRODUCT SELECTION GUIDE

	Structural Square Edge (CD Grade)	Flooring (CD Grade)	Roofing (DD Grade)
Product Description	CD face grade sheets are available in a range of thicknesses and sizes	Solid sanded C grade surface with tongue and groove profile on long edges	Unfilled D grade surface with tongue and groove profile on long edges
Recommended Applications	Substrate for flexible coverings requiring a smooth substrate and where avoidance of visible surface indentations is critical. Use as a substrate for flexible roof and deck membranes and thin roofing tiles		Substrate for coverings with the ability to span holes in the D face grade (up to 75 mm in diameter) such as asphaltic roof tiles and torch welded polyester reinforce membranes Do not use under flexible membrane coverings or where avoidance of visible surface indentation is critical
Face Grades	Front: C solid sanded Back: D unsanded		Front & Back: D unsanded
	Refer to Table 1 for range and treatment options		
Product Features	Blocking required to support all edges	Second void free layer under surface veneer for increased protection against punching through the first veneer under high point loads & increased moisture resistance Blocking not required to support tongue and groove edges (unless otherwise specified)	15 mm thickness specifically designed for use under shingles and tiles that have a courser finish Unsanded surface for extra strength and grip for installers on steep roofs Blocking not required to support tongue and groove edges (unless otherwise specified)
Thicknesses Available	12, 15, 17, 19, 21, 25 mm	15, 17, 19, 21, 25 mm	15, 17 mm
Sheet Sizes Available	2400/2700 x 1200 mm		
Stress Grades Available	F8 (F11 ¹ available upon request)	F8 (F11 ¹ available upon request) 19 mm Longspan supplied F11 ¹ as standard	F8 & F11 ¹
Treatment	Untreated, H3.2 CCA and H3.1 LOSP	Untreated, H3.2 CCA, (H3.1 LOSP available upon request)	
Span Capabilities	Refer to frame spacings in Tables 13A and 13C		

¹ Where the stress grade F11 is referred to in all CHH Woodproducts plywood literature actual stress grade properties of panels are F11 parallel to the face grain and F8 perpendicular to the face grain.

5.4 FRAME SPACINGS FOR ECOPLY® ROOFS AND DECKS

TABLE 13A: ROOFING - SHEATHING, NON TRAFFICABLE, ABOVE 2 DEGREE PITCH

Application	Roof Pitch	Stress Grade	Maximum Wind Zone	Maximum frame centres (mm) for Ecoply with face grain across framing				
				Ecoply® nominal thickness (mm)				
				15	17	19	21	25
Sheathing, non trafficable roof for all roof pitches above 2 degrees Suitable for roof mass up to 30 kg/m ² (additional to Ecoply weight or 40 kg/m ² including Ecoply)	>2°	F8	Extra High	600	600	800	800	900
		F11	High	900	900			
			Very High	800	900			
	>20°	F11	Very High	900	900			
			Extra High	800	800			

Suggested applications include substrates for Asphalt Single and Membrane type roofs.
The above suggested maximum framing spans are based on the following deflections criteria:

- Under a short term 1kN point load, deflection is less than Span/130
- Under a long term self weight load, deflection is less than Span/400
- Under a short term wind gust load, deflection is less than Span/150

TABLE 13B: SUB-SHEATHING

Application	Maximum frame centres (mm) for Ecoply® with face grain across framing					
	Ecoply® nominal thickness (mm)					
	12	15	17	19	21	25
Under steel or self supporting cladding for support of building paper or lateral diaphragm action. Sag not critical	800	1200				

TABLE 13C: DECKING

Application	Maximum frame centres (mm) for Ecoply® with face grain across framing			
	Ecoply® nominal thickness (mm)			
	17	19	21	25
1. Trafficable roof decking Limited by dynamic response of roof as floor	540	600	600	750
2. Roof decking to clause 8.5.5.1 c) of E2/AS1*	400	400	400	400

* The current requirement in E2 AS1 is extremely conservative when compared with calculations determined for other applications using VMI Clause 6 and calibrating the spans against codes of practice from North America and Australia. CHH Woodproducts recommends designers consider the alternative solution in row 1 of Table 13C for membrane decking.

Unless otherwise stated spans apply equally to square edge or tongue and groove panels.

Check Table 1 for availability of grades and lengths to match span multiples in Table 14

- Use the next lower recommended frame spacing or thicker Ecoply® where appearance is critical
- To suit trusses at 900 centres, 2700 long sheets are available. See Table 14

TABLE 14: FRAME SET OUTS (MM) TO MATCH 2400 MM AND 2700 MM SHEET MODULES

Length (mm)	Frame Spacing			
2400	400	480	600	800
2700	450	540	675	900

Limitation for the use of Table 14

CHH Woodproducts does not have access to information about designs for specific sites. Table 14 is a guide to estimate the initial selection of a span for design. Each site should be evaluated by qualified persons to ensure all loading parameters and site conditions have been considered, and appropriate changes should be made by the building designer.

5.5 ROOFING - DESIGN CONSIDERATIONS

Durability

In general, H3.2 CCA treatment of Ecoply® plywood with waterborne preservatives is recommended for roofing.

Roofing materials

Various roofing materials used over Ecoply plywood have different durability expectations, normally in excess of the 15 years required by the NZ Building Code Clause B2. Durability of the roofing is subject to the specifications, installation and maintenance requirements of the roofing manufacturer. The durability of the Ecoply can only be assured as long as the overlying roofing and detailing excludes moisture. With good building practice and maintenance, roofing materials can be repaired or replaced at regular intervals to achieve life from the Ecoply in excess of the original roofing. With this proviso the durability of Ecoply structural plywood will be in excess of 50 years if installed in accordance with instructions and limitations in this brochure and the roof system is adequately maintained.

High humidity, condensation and solar driven moisture

Where the moisture content of wood may exceed 18% for prolonged periods, Ecoply must be H3.2 CCA treated, to resist decay hazard. This includes Ecoply used under roof coverings that may be subject to condensation, or where rain moisture soaked in the roof covering can be driven into the Ecoply by the sun. Appropriate building detailing and ventilation is recommended which can reduce the need for treatment.

Roof ventilation

Poorly ventilated spaces can develop very high temperature and moisture levels. The most likely source of moisture is the condensation of vapour from warm interior air on the underside of cold roofing. Good ventilation can remove the need for treatment by removing excess moisture vapour

in warmer climates but in regions where winter nights are consistently colder, H3 treated Ecoply is recommended. However, the use of H3 treated Ecoply is not an excuse for poor ventilation design. Moisture induced decay is only one issue. If incorrectly detailed, roof spaces can be very tight and the dark colour of many roofing materials means that excessive heat can build up causing distortion in plywood or even framing members. Use the suggested details or alternatives to suit. Designers must consider roofing type, seasonal conditions, wind effects and the intended use of the building.

As a minimum, CHH Woodproducts recommends a vent area of 1/300th of the ceiling plan area (approx 3350 mm² per square metre of ceiling) equally distributed at the eaves and ridge to allow free flow under the Ecoply, up the roof slope, and out.

Roofing material suppliers should detail vent systems suited to their specific membrane or tile roofing. Proprietary ridge capping profiles or vents are available from roofing suppliers.

Detail gaps of 25 mm in the plywood at ridges, and at walls where a roof slopes up to an upper storey. For flat roofs, natural ventilation flows may be impeded. Use proprietary roof vents. Consider forced ventilation as appropriate.

Bubbling

Plywood bubbling occurs when moisture trapped in knot holes in inner veneers expands as the temperature rises. This moisture will dissipate through the face veneer and will not affect the structural integrity of the plywood panel. As membrane coverings can prevent moisture dissipation, Ecoply Flooring and Structural Square Edge CD is recommended if the visual appearance of bubbling is not acceptable, or a high visual finish is required.

Soil

Ecoply plywood (untreated or H3 treated) must not be allowed to come in contact with soil. Surfaces, flashings and gutters should be detailed to avoid trapping detritus and moisture.

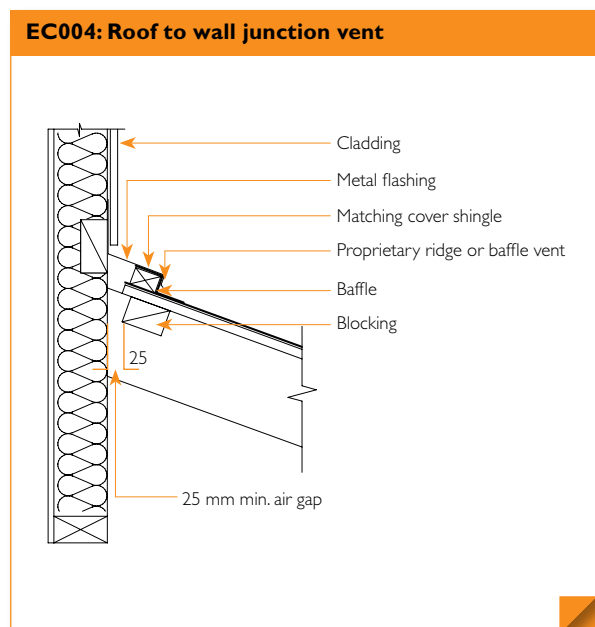
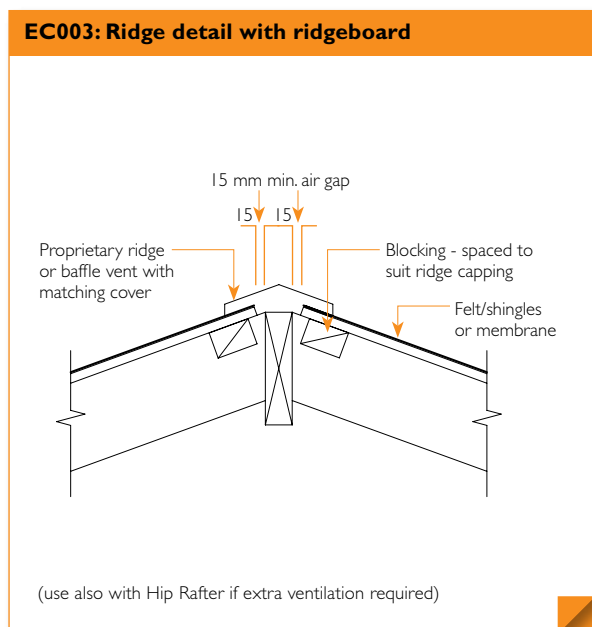

EC005: Truss ridge detail

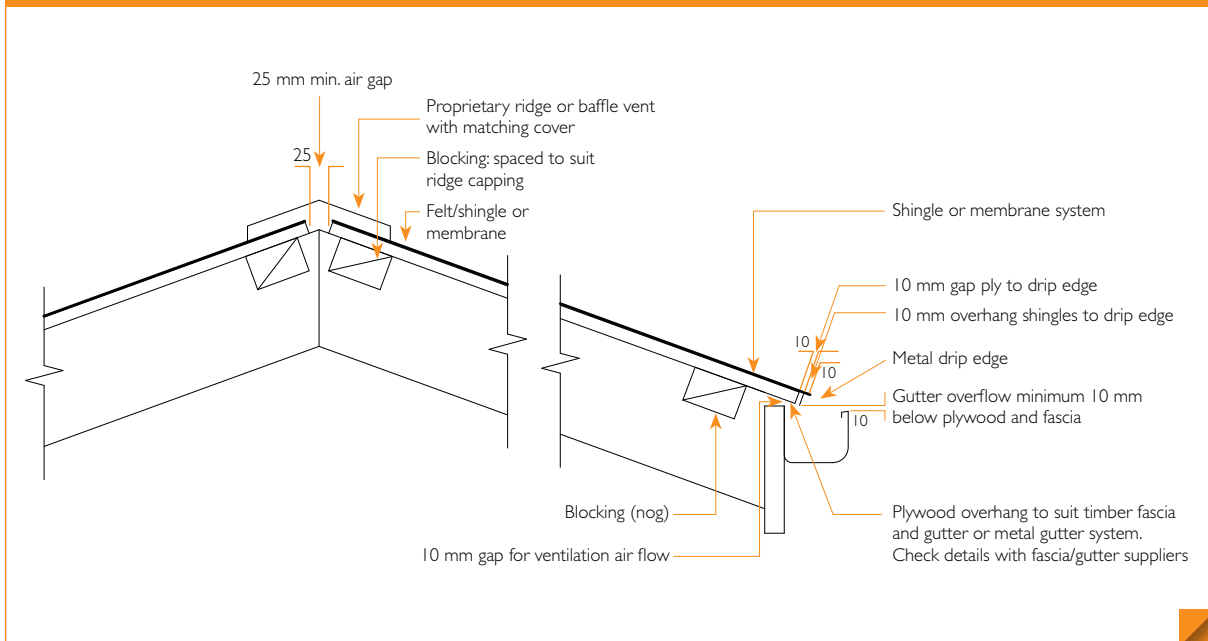

Rain wetting and construction time

Untreated Ecoply® will withstand a reasonable amount of rain wetting and exposure during construction for up to three months. In extreme weather conditions of high temperature and/or high rainfall this period may be less. Appearance issues such as discolouration and checking of the sheet surface can be expected if Ecoply is exposed. For roofs uncovered for longer periods use H3 treated Ecoply to lower the risk of decay. Return Ecoply to below 18% moisture content before installing moisture sensitive materials, coverings, coatings or adhesives. Where a high visual finish is desired (such as membrane roofing and decking) protect Ecoply from exterior moisture during construction. For detailed information see section 5.1 Flexible Membrane Systems.

Gutter details

Where Ecoply structural plywood sub-sheathing supports roofing at gutters, a metal drip edge must be provided with appropriate gaps to shed water. Gutters should have a front edge overflow or ends lower than the back to shed water overflow away from framing and sub-sheathing Ecoply. H3 treatment is recommended for Ecoply sheets that protrude into gutters, with regular maintenance to avoid leaf mould (soil) development. Do not expose untreated Ecoply to gutter splash or moisture.

Fire

Plywood is combustible but may be used as a roof substrate for all purpose groups subject to the provisions of Department of Building and Housing Acceptable Solution C/AS1: clause 7.1 and 7.9. For purpose groups SC and SD a 19 mm Ecoply panel complies with the requirement of Clause 7.

Fastener spacing for wind suction

Wind pressure applies withdrawal loads to nails holding plywood to purlins and trusses. For the frame spacing in Table 13A designers may use the following guidelines for frame spacing up to 900 mm throughout New Zealand for normal urban wind conditions.

The main body of the roof

2.8 mm nails spaced at 150 mm centres on all cross framing. Minimum nail length 60 x 2.8 mm.

Roof edges

All Ecoply structural plywood used at higher suction zones at the roof edges, gutters, eaves and gable ends must be supported on framing, and fixed at 100 mm centres with minimum 60 x 3.05 mm nail length. Suction zones are interpreted from AS 1170 as being within 20% building length or width of a gable end, or gutter or ridge.

Designers and builders should review site conditions to ensure adequate fixing is applied. Buildings in exposed sites and lee zones should be specifically designed using the loading standard (AS/NZS 1170) and the timber structures standard NZS 3603. In some wind conditions, the tiles themselves may be sucked from the plywood. Use a consulting engineer to assess site conditions, calculate wind pressures for the specific site, and determine the fastening and span requirements, and to check that the truss system can resist the loads being applied through the plywood.

Fixing of roofing

Fixing methods for tile, shingle and membrane systems must be designed for the expected wind and weather exposure to protect the Ecoply substrate. Some shingle systems may not be used in very high or cyclonic wind zones.

Follow the specifications of the roofing manufacturer and refer to the appropriate BRANZ Appraisals.

5.6 ROOFING - INSTALLATION

Framing

Frames should be at spacings to suit plywood thicknesses in Table I 3A. Additional requirements for roof framing are:

- Ensure top edges of framing are properly aligned
- Use dry Laserframe®, hyJOIST® or hySPAN® framing to lower moisture level in roof spaces, second floor spaces, and reduce differential truss, rafter or joist deflections

Blocking (nogs, dwangs):

- Block all edges of Ecoply® Structural Square Edge plywood
- Block all edges at the ridge and gutter lines to prevent sag at capping or gutters

- Block for high face loads or under areas accessed for maintenance
- Blocking within the body of the roof is not required under tongue and grooved edges when using Ecoply Flooring & Roofing, unless required for framing stability or the plywood is being used as a diaphragm to resist horizontal wind or earthquake loads. In this case fixings transfer shear across the joints and details should be specified on drawings
- Use blocking on the flat to provide gaps where air flow is needed for ventilation
- Specific roofing suppliers may require blocking to suit their system

EC006: Sheet and framing layout

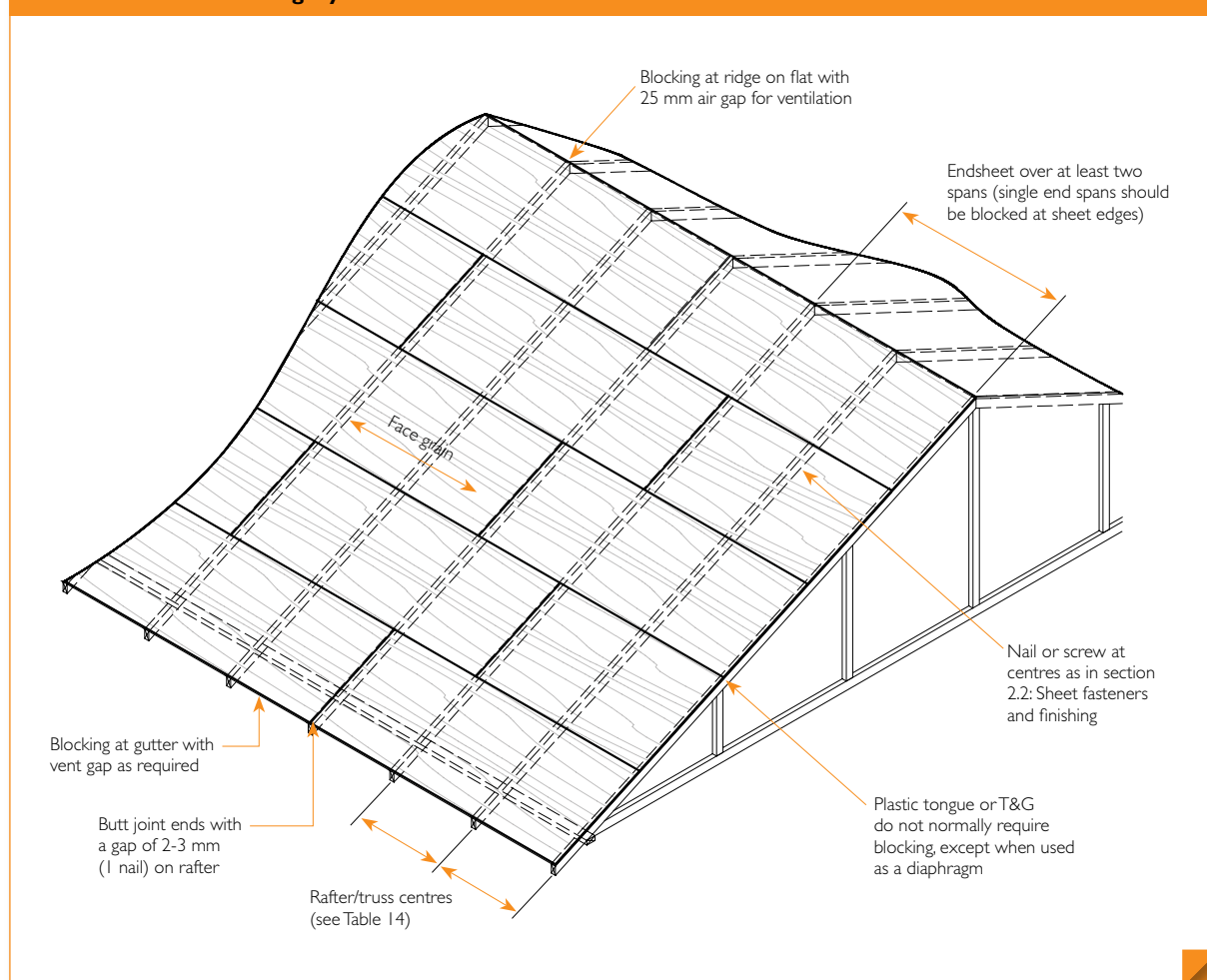

Sheet layout

- Ensure Ecoply sheets are dry before installation
- Place face grain at right angles to supports
- Sheets must be continuous over at least two spans (three framing members)
- Lay the sheets in a staggered pattern
- Allow sufficient clearance inside confining structure such as concrete or brick walls adjacent to the roof. Use extra allowances with large areas
- Allow clearance for ventilation as required

Fixing of sheets

Ecoply® may be fixed to different types of framing with nails, screws or a combination of fasteners and construction adhesives.

Fasteners should be corrosion resistant to a level appropriate to the end use life expectancy (15 or 50 years) and expected exposure to moisture. Where fasteners are in contact with H3.2 CCA treated timber or plywood, fasteners must be a minimum of hot dip galvanised. In certain circumstances stainless steel fasteners may be required. Refer to section 4 of NZS 3604 for these circumstances. Where stainless steel nails are required, annular grooved nails must be used.

The integrity of a plywood based roof system is directly related to how well the panels are fixed to the framing. Ecoply must be fixed to resist wind suction loads, and to maintain surface qualities of the overlying roof covering. Minimum fastener specifications are in Table 7 and section 2.2: Sheet fasteners and fixing.

- Always refer to the roofing system supplier for system requirements
- For roofing, check the additional requirements according to wind exposure
- For high wind zones (over 44 m/s), very exposed sites, cyclonic conditions or roofs above 10 metres height, carry out specific structural design to the relevant standards
- Screw fixing must be used for membrane roofing, and is preferred for all systems because of increased holding power and avoidance of head popping

Fixing to timber frames

- Ring shank nails or annular grooved nails or screws are recommended for additional holding power
- Use flathead nails. Do not use jolt or bullet head nails
- Stainless steel nails must be annular grooved
- Ensure fastener is compatible with the roofing cover (consult roofing system supplier)
- Staples may be used provided that the withdrawal load is equivalent to the hand driven galvanised flathead nail. A suggested minimum is a 50 mm long staple with 12 mm crown and legs 1.8 mm diameter. Space staples 20% closer than nails. Refer manufacturer for corrosion resistance and durability

Fixing to steel frames

- Fix directly to roll formed steel (up to 2 mm thick) with self-drilling, self-tapping screws. If plywood gets damp and expands, screws in thicker steel may break. Keep Ecoply dry or use larger screws or;
- Bolt or screw battens to the steel and apply Ecoply as above for timber. Ensure that battens have adequate thickness for the minimum nail or screw length

6.0 FLOORING

The following section covers the use of Ecoply® Flooring plywood used as a flooring substrate with flexible and rigid

overlays. Ecoply Flooring is suitable as a substrate for overlays such as carpet, linoleum, tiles and membrane products.

6.1 FLOORING - RANGE

- Ecoply Flooring contains a second void free layer under the surface veneer for increased protection against moisture bubbles and punch through of the first veneer under high point loads than normal Ecoply Structural Square Edge plywood
- The tongue and groove on long sheet edges does not require support blocking under the joint (unless otherwise specified)
- Supplied in F8 stress grade (F11 available upon request). Ecoply 19 mm Longspan Flooring supplied as standard in F11¹ stress grade
- Supplied as standard with a sanded C grade surface with D grade back
- Sanded B grade surface is available in 19 mm thickness (untreated only) for clear finish applications. Designers must expect the surface to dent or mark more easily than hardwood flooring systems as Ecoply is manufactured from relatively soft radiata pine.
- Available untreated or H3.2 CCA treated, (H3.1 LOSP treated available upon request)
- Refer to Table 1 for range and treatment options

6.2 FLOORING - INSTALLATION

TABLE 15: FLOORING FRAME SPACINGS

Application	Maximum frame centres (mm) for Ecoply® Flooring with face grain across framing				
	Ecoply® Flooring nominal thickness (mm)				
	15	17	19	21	25
1. Domestic flooring 2kPa - 1.8kN	480	540	600 F11 ¹ Longspan	600	750
2. Institutional and public assembly up to 4kPa - 2.7kN		300	480	540	750
3. Institutional and crowd assembly up to 5kPa - 3.6kN			400	450	600
4. Corridors, industrial up to 5kPa - 4.5kN			300	400	540
5. Domestic garage floor** 2.5kPa - 9kN					300

** Provide blocking to all edges of the sheet.

- Use the next lower recommended frame spacing or thicker Ecoply flooring where appearance is critical
- To suit frames at 900 centres, 2700 long sheets are available. See Table 14

¹ Where the stress grade F11 is referred to in all CHH Woodproducts plywood literature actual stress grade properties of panels are F11 parallel to the face grain and F8 perpendicular to the face grain

Floor loads

For domestic garage floors blocking is required under all edges to control wheel loads on the tongue. Testing with 113 mm diameter load head (0.01 m²) confirms commercial floor capabilities.

Refer to Table 14 to match frame set outs with 2400 mm and 2700 mm sheet modules.

Framing

- Joist spacings should be at spacings to suit plywood thicknesses in Table 15
- Use dry Laserframe®, hyJOIST® or hySPAN® framing to achieve a moisture content of 18% or less

Blocking

- Blocking within the body of the floor is not required under tongue and groove edges unless otherwise specified (such as in domestic garage floors)

Sheet layout

- Ensure Ecoply® sheets are dry before installation
- Place face grain at right angles to supports
- Sheets must be continuous over at least two spans (three framing members)
- For panels at floor edges where a continuous two span coverage is not possible, sheet edges must be supported by blocking
- Lay sheets in a staggered pattern
- Allow clearance for ventilation as required

EC007: Ecoply® Flooring layout

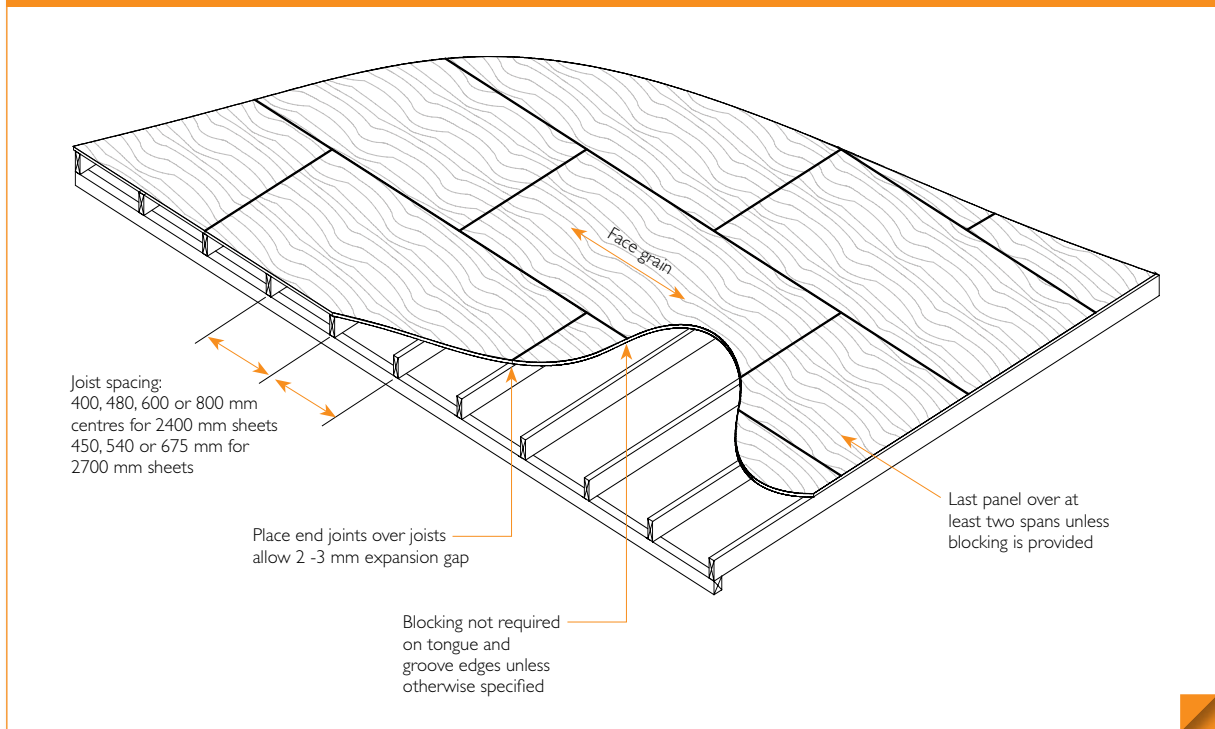

Fastener selection and treatment

Fasteners should be corrosion resistant to a level appropriate to the end use, life expectancy (15 or 50 years) and expected exposure to moisture.

Where fasteners are in contact with H3.2 CCA treated timber or plywood, fasteners shall be a minimum of hot dip galvanized. In certain circumstances stainless steel fasteners may be required. Refer to section 4 of NZS 3604 for these circumstances. Where stainless steel nails are required, annular grooved nails must be used.

Fasteners and fixing of sheets

- Ecoply Flooring may be fixed with nails or screws or a combination of mechanical fasteners and construction adhesives
- For fastener specifications (including lay out and sizes) refer to section 2.2: Sheet fasteners and fixing
- For construction adhesive specifications refer to section 2.3: Adhesives
- Ring shank or annular grooved nails, or screws are recommended for additional holding power
- To reduce the risk of fastener popping or floor squeak the use of construction adhesives is advised.
- Do not use jolt or bullet head nails

6.3 FLOORS - FINISHING

- Overlays and coatings should be applied following the manufacturer's specifications
- Avoid heavy sanding that may remove the critically important structural face veneer
- Adhesives must be compatible with CCA (Copper Chrome Arsenic) treatment in H3 treated sheets. Compatibility can often be improved by lightly washing, scrubbing and drying the plywood surface prior to fixing
- Where clear or stained finishes are desired, designers should select sheets and protect the floor as much as possible from the weather and construction activities
- Ecoply is made from relatively soft radiata pine and as such will dent or mark more easily than hardwood flooring systems. This is to be expected and designers must consider the long term appearance requirements of the project. Ecoply Flooring is a good substrate for harder wearing flooring overlays, and is not primarily intended for clear finishing, especially if it is exposed to moisture during construction
- For improved surface finish floors should be protected from weather during construction as soon as possible

8.0 FREQUENTLY ASKED QUESTIONS

Q: How much should be allowed for expansion?

A: Allow 2 – 3 mm between square edges of Ecoply® sheets. If using Ecoply Flooring, a 5 mm expansion gap is recommended at the perimeter of the floor or deck. Check by calculation for large areas.

Q: Can power driven nails be used to fix Ecoply?

A: Paslode power driven nails have been tested for fixing Ecoply and Shadowclad® products for particular bracing and cladding applications. For power driven nail specifications refer to technical note *Paslode nail matrix* downloadable from www.chhwoodproducts.co.nz. Use the Paslode Impulse Compact Nailer fitted with a No Mar(k) work contact element to eliminate any contact marks on the plywood. Adjust the work contact element to the flush position and fire the nail at 90° to the work surface. Hammer any nails flush which are left proud. Do not over drive.

Q: How close to sheet edges can I nail?

A: Fixings can be placed a minimum 7 mm from the sheet edge.

Q: Do I have to use stainless steel nails when using Ecoply for bracing?

A: Where fasteners are in contact with H3.2 CCA treated timber or plywood, fasteners must be a minimum of hot dip galvanised. In certain circumstances stainless steel fasteners may be required. Refer to Table 8 of the Ecoply Specification and Installation Guide for these circumstances. Where stainless steel nails are required, annular grooved nails must be used.

Q: What is the weight of Ecoply?

A: Refer to Table 4a for weight (kg/m²) of different Ecoply thicknesses.

Q: What is the R-value of Ecoply?

A: The thermal resistance or insulating effectiveness of plywood panels can be calculated using NZS 4214. e.g. plywood has a conductivity (k) of 0.13 W/mK so a 12 mm panel has a thermal resistance $R = 0.012/0.13 = 0.09$.

Q: Are there any compatibility issues when using Ecoply with other materials?

A: Adhesives for flexible rubber membranes may react with LOSP treatment and should therefore only be applied to H3.2 CCA treated Ecoply unless the membrane supplier advises differently. Check with the membrane manufacturer if in doubt. H3.2 CCA treatment is also corrosive and this must be taken into account when specifying H3.2 CCA treated plywood next to metals. For further guidance, refer to Tables 21 and 22 in *Acceptable Solution E2/AS1*.

Q: Can Ecoply be used as a rigid sheathing (air barrier)?

A: Ecoply Barrier has been developed as a rigid air barrier. Refer to Ecoply Barrier Specification & Installation Guide for further information.

Q: What is the relevance of AS/NZS 2269?

A: Ecoply structural plywood is manufactured to AS/NZS 2269 Plywood Structural. This Standard is referenced by the NZ Building Code Compliance Documents including NZS 3602 *Timber and Wood-based Products for Use in Building*, NZS 3603 *Timber Structures*, NZS 3604 *Timber Framed Buildings*, AS/NZS 1604.3 *Specification for Preservative Treatment, Part 3: Plywood and Acceptable Solution E2/AS1 External Moisture*. Plywood not manufactured to AS/NZS 2269 does NOT meet the requirements of these NZ Building Code Compliance Documents.

Q: What is the relevance of the PAA stamp?

A: Ecoply is manufactured under a third party audited, product quality control programme by the Engineered Wood Products Association of Australasia (EWPAA) to monitor compliance with AS/NZS 2269. Given that compliance with Standards is not actively policed by Standards New Zealand, this third party auditing provides important peace of mind for users and consumers of Ecoply products.

Q: What is marine ply?

A: Marine plywood manufactured to AS/NZS 2272 Plywood Marine may contain species of low durability (source: *BRANZ Good Practice Guide – Timber Cladding*). Whilst marine plywood has a Type A glue bond, it is generally specified for its high surface appearance grade and lack of core knots as opposed to structural performance. AS/NZS 2272 limits marine plywood to a number of approved species that pass stringent property requirements for things like moisture permeability. These requirements are different from those in standards from other countries. Marine plywood is rarely treated as it is usually coated with resin or fibreglass or a paint finish for long term durability.

Q: What should a specification for structural plywood include?

A: A specification for structural plywood should include:

Specification check list	Example
Quantity/size	20 sheets of 2400 x 1200
Thickness	12 mm
Edge finish	Square edge
Brand name	Ecoply® structural plywood
Reference to Standard	To AS/NZS 2269
Stress grade/layup	F8 (12-24-5)
Surface grade/bond type	CD A-Bond ²
Accreditation	EWPAA product certified ³

¹ Stress grades may vary between different manufacturers and products.

² Type A-bonds are suitable for permanent exposed applications and structural applications.

³ The EWPAA JAS-ANZ Product Certification Mark certifies that Ecoply structural plywood products have been manufactured under a third party audited joint product certification programme to monitor compliance with AS/NZS 2269.

Q: What are F-grades?

A: The stress grading system is a ranking system which utilises the symbol F and a suffix 8, 11 etc as a code to apply a full suite of strength and stiffness properties to plywood products of that stress grade. For plywood of a given thickness, the higher the F-grade, the further it will span. For load bearing applications (e.g. flooring, roofing) the required F-grade as well as the plywood thickness must be specified to achieve the required span. F8 is the most common structural plywood grade found in New Zealand. All Ecoply® structural products are F8 with the exception Ecoply 15 mm roofing and Ecoply 19 mm Longspan Flooring. Other Ecoply Flooring products are also available in F11 upon request.

Q: What are surface/appearance grades (eg CD)?

A: Appearance grades (eg BB, BD, CD, DD) denote the appearance grade of the plywood including the number and size of knot holes as defined in AS/NZS 2269 and summarised in Table 2 of this manual. The first letter describes the appearance of the face veneer and the second letter describes the back face.

Q: How long can Ecoply be left exposed to the weather?

A: Untreated Ecoply will maintain its structural integrity when exposed to the weather during construction for up to 3 months. The surface colour will start to silver off and surface checking will become evident. Where the finished appearance of the Ecoply is important, it should be protected during construction. Ecoply is also available H3 treated to resist decay or insect hazard. When used in accordance with this manual, it can be specified to meet the durability requirements of the NZ Building Code, however appearance issues such as surface checking may still occur dependent upon the degree of exposure to weather during construction.

Q: What treatment levels and types are used for Ecoply?

A: Ecoply is available untreated or preservative treated. Ecoply is treated to the H3 hazard class for above ground use. The standard Ecoply treatment type is H3.2 CCA (Copper Chrome Arsenate) although H3.1 LOSP Azole (Liquid Organic Solvent Preservative) may also be specified where a clear treatment is required. LOSP Azole is the standard treatment type for BB, BD, Ecoply Grooved Lining and Shadowclad®. CCA treatment gives the plywood sheets a green tinge and the drying process after CCA treatment may leave fillet marks on the face of the sheet.

Q: Does Ecoply have to be treated when used as structural bracing?

A: Ecoply used as bracing must be treated unless it is installed in an interior dry situation. Note, behind exterior cladding and in cavities (even if the Ecoply is covered with building wrap) are not considered to be an interior dry situation.

Q: Do I have to re-treat cut edges of treated Ecoply?

A: It is important to re-treat any cuts and holes with a brush on remedial treatment such as Metalex Clear End Seal.

Q: What type of glue is used to manufacture Ecoply?

A: Phenol formaldehyde (PF) resins are used to bond the plywood veneers. This forms a Type A (Marine) bond suitable for structural applications and exterior use. Phenol formaldehyde resins are dark red/brown in colour. Product details printed on the back of Ecoply sheets indicate the 'A Bond'.

Q: Does Ecoply emit formaldehyde?

A: Formaldehyde occurs naturally in the environment and is emitted by processes such as combustion, decay and naturally by all timber species. Ecoply and Shadowclad meets the lowest formaldehyde emission class (E₀ - less than 0.5 mg/litre). Actual formaldehyde emissions have been tested to be less than 0.3 mg/litre.

Q: How should Ecoply be installed to maximise its stiffness properties?

A: Structural plywood has greatest stiffness along the long grain of the sheet (i.e. along its length). Therefore, flooring/roofing should be laid across joists/rafters rather than parallel to them.

9.0 REFERENCES AND SOURCES OF INFORMATION

- New Zealand Building Code
- CHH Woodproducts technical notes - downloadable from www.chhwoodproducts.co.nz/document-library
- NZS 3640:2003 "Chemical Preservation of Round and Sawn Timber"
- NZS 3602:2003 "Timber and Wood-based products for use in Buildings"
- NZS 3603:1993 "Timber Structures Standard"
- NZS 3604:2011 "Timber Framed Buildings"
- AS/NZS 1170:2011 "Structural design actions"
- AS/NZS 2269:2008 "Plywood Structural"
- AS/NZS 1604.3:2010 "Specification for Preservative Treatment, Part 3: Plywood"
- AS 1684:2010 "Residential Timber Framed Construction"
- AS 1720:2010 "Timber Structure"
- US Product Standard PSI-95
- Acceptable Solution 'E2/AS1 – External Moisture'
- Acceptable Solution 'B2/AS1 – Durability'
- BRANZ Bulletin 345: Flat membrane roofs – design and installation
- BRANZ Bulletin 346: Flat membrane roofs – materials
- BRANZ Bulletin 289: Asphalt shingle roofing
- BRANZ Appraisals 307, 404, 411
- Shadowclad® Specification & Installation Guide
- Ecoply® Barrier Specification & Installation Guide
- Material Safety Data Sheets
- APA (www.buildabetterhome.org)
- EWPA (www.ewp.asn.au)

Standards can be purchased online at www.standards.co.nz

Building Code Compliance Documents can be downloaded free of charge at www.dbh.govt.nz



CarterHoltHarvey
Woodproducts New Zealand

Private Bag 92-106
Auckland
New Zealand
Freephone: 0800 326 759
Freefax: 0800 746 400

www.chhwoodproducts.co.nz

December 2011