

# Shadowclad® Bracing Specification – SC1

January 2012

## Single Sided Shadowclad Brace Used as a Dual Cladding and Structural Bracing Element

Specification No.	Minimum Wall Length	Lining Requirements	Bus/m Wind	Bus/m Earthquake
SC1	0.6m	Shadowclad one side	105	120

## Framing

Wall framing must comply with:

- NZBC B1 - Structure: AS1 Clause 3 Timber (NZS 3604:2011)
- NZBC B2 - Durability: AS1 Clause 3.2 Timber (NZS 3602)

Framing dimensions and height are as determined by the NZS 3604 stud and top plate tables for load bearing and non load bearing walls. Kiln dried verified structural grade timber must be used. Machine stress graded timber, such as Laserframe®, is recommended.

## Bottom plate fixing

Use GIB Handibrac® hold-down connections at each end of the bracing element. Refer to manufacturer installation instructions, supplied with the connectors, for correct installation instructions and bolt types to be used for either concrete or timber floors. Within the length of the bracing element, bottom plates are fixed in accordance with the requirements of NZS 3604.

## Lining

One layer of Shadowclad® fixed directly to framing or over cavity battens. If part sheets are used, ensure nailing at required centres is carried out around the perimeter of each sheet or part sheet.

## Fastening the Shadowclad

### Fasteners

Fasten with 60 x 3.15 mm galvanised or stainless steel flat head nails for direct fix or over cavity battens. Place fasteners no less than 7 mm from sheet edges.

### Fasteners for H3.2 CCA treated Shadowclad

Use stainless steel fasteners where fasteners are in contact with H3.2 CCA treated timber or plywood.

Where stainless steel nails are required, annular grooved nails must be used.

Refer to table 8 of the Shadowclad Specification and Installation Guide for further fastener selection advice.

### Fastening centres

Fasteners are placed at 150 mm centres around the perimeter of each sheet and 300 mm centres to intermediate studs.

Where more than one sheet forms the brace element each sheet must be nailed off independently.

### Fastening to cavity battens

The brace element may be fixed over cavity battens. The cavity battens must be a minimum of 40 x 20 mm nailed staggered formation at 150 mm centres to studs around the perimeter of the brace element, and nailed to the intermediate studs within the element at 300 mm centres, 60mm x 3.15 mm flat head galvanised or annular grooved stainless steel nails

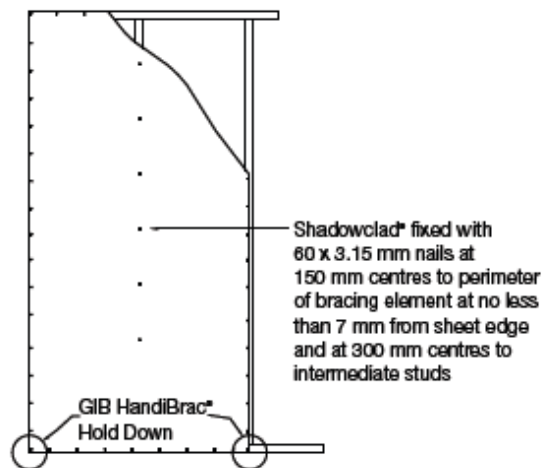

## Coating Requirements for Shadowclad as Structural Bracing

Shadowclad panels may be used as a dual cladding and structural bracing system either direct fixed or over a ventilated cavity.

Where Shadowclad is to be used as both cladding and structural bracing the following is required:

- Panels must be coated with a three coat acrylic coating system such as a good quality paint or film forming stain. (Penetrating stains do not meet this requirement)
- Coating colours must have light reflectance value (LRV) of 40% or more
- Minimum total coating system film build of 90 microns
- Coatings must be regularly maintained as part of a normal building maintenance program throughout the life of the building

Shadowclad Bracing Systems are designed to meet the requirements of the New Zealand Building Code and have been tested and analysed using the P21 method referenced in NZS3604:2011 listed as an acceptable solution B1/AS1 Structure. Testing was carried out using Shadowclad and Laserframe SG8 timber framing manufactured by Carter Holt Harvey Limited trading as Carter Holt Harvey Woodproducts New Zealand, and GIB® products manufactured by Winstone Wallboards Ltd. **Substituting materials may compromise performance of the system.** GIB® and GIB Handibrac® are registered trade marks of Fletcher Building Holdings Ltd.